

# Annual Report 2025







EXCELENCIA  
MARÍA  
DE MAEZTU



Institute for Cross-Disciplinary Physics and Complex Systems

<http://ifisc.uib-csic.es/>



@IFISC\_mallorca



<http://www.facebook.com/ifisc>



<http://www.youtube.com/user/IFISCseminars>



<https://bsky.app/profile/ifisc.uib-csic.es>

An electronic version of this report  
can be downloaded from:

<https://ifisc.uib-csic.es/en/about-ifisc/annual-reports/>

# Index

|                                 |   |  |
|---------------------------------|---|--|
| PRESENTATION AND RESEARCH AREAS | 1 | 010 1.1. IFISC RESEARCH AREAS<br>014 1.2. "MARIA DE MAEZTU" EXCELLENCE AWARD<br>017 1.3. IFISC SERVICE UNIT: DATANALYTICS@IFISC<br>018 1.4. IFISC STRUCTURE CHART<br>019 1.5. 2024 REPRESENTATIVE RESEARCH RESULTS   |
| PERSONNEL                       | 2 | 035 2.1. PERMANENT SCIENTIFIC STAFF<br>037 2.2. TENURE TRACK AND SENIOR RESEARCH FELLOWS<br>037 2.3. SCIENTIFIC ASSOCIATES<br>037 2.4. POSTDOCTORAL RESEARCH ASSOCIATES<br>038 2.5. PHD STUDENTS<br>040 2.6. TECHNICAL AND ADMINISTRATIVE SUPPORT<br>041 2.7. VISITORS<br>043 2.8. MASTER AND COLLABORATION STUDENTS<br>044 2.9. HUMAN RESOURCES OVERVIEW                      |
| RESEARCH PROJECTS AND FUNDING   | 3 | 050 3.1. RESEARCH FUNDED BY THE EUROPEAN COMMISSION<br>051 3.2. RESEARCH PROJECTS OF THE SPANISH NATIONAL PLAN FOR SCIENCE<br>053 3.3. OTHER PUBLIC FUNDING<br>054 3.4. RESEARCH PROJECTS AND COLLABORATION NETWORKS WITH PARTICIPATION OF IFISC MEMBERS<br>055 3.5. RESEARCH CONTRACTS<br>056 3.6. NON DISCLOSURE AND COLLABORATION AGREEMENTS WITH NON ACADEMIC INSTITUTIONS |
| IFISC SEMINARS                  | 4 | 059 IFISC SEMINARS 2025  |
| PUBLICATIONS                    | 5 | 063 PUBLICATIONS 2025  |
| CONFERENCES AND WORKSHOPS       | 6 | 067 6.1. PRESENTATIONS AT SCIENTIFIC CONFERENCES<br>068 6.2. ORGANIZATION OF CONFERENCES AND WORKSHOPS   |
| OTHER ACTIVITIES                | 7 | 073 7.1. PHD PROGRAM<br>074 7.2. SURF@IFISC<br>075 7.3. IFISC MASTER<br>076 7.4. OTHER POSTGRADUATE COURSES<br>077 7.5. MEMBERS OF EDITORIAL BOARD OF SCIENTIFIC JOURNALS<br>078 7.6. SCIENTIFIC COMMITTEES<br>079 7.7. RESEARCH STAYS IN OTHER CENTERS  |
| OUTREACH ACTIVITIES             | 8 | 083 8.1. POSTER PARTY<br>084 8.2. 11F WOMEN IN SCIENCE<br>084 8.3. "CIÈNCIA PER TOTHOM"<br>085 8.4. "CIENTÍFICOS EN PRÁCTICAS"<br>086 8.5. "NIT DE LA RECERCA"<br>088 8.6. OTHER OUTREACH EVENTS<br>090 8.7. PRESS AND MEDIA<br>091 8.8. SOCIAL MEDIA IMPACT SUMMARY   |
| APPENDIX                        |   | 095 A.4. IFISC SEMINARS AND TALKS 2025<br>099 A.5. PUBLICATIONS<br>105 A.6. PRESENTATIONS AT CONFERENCES AND ACADEMIC CENTERS<br>113 A.7. OTHER ACTIVITIES<br>114 A.8. PRESS AND MEDIA   |



# 1

## PRESENTATION AND RESEARCH AREAS





**IFISC (Institute for Cross-Disciplinary Physics and Complex Systems)** is a joint research institute of the **University of the Balearic Islands (UIB)** and the **Spanish National Research Council (CSIC)** created in 2007 building upon the former Cross-Disciplinary Physics Department of the Mediterranean Institute for Advanced Studies (IMEDEA).

IFISC has been awarded by the Spanish Research Agency (AEI) with the **Maria de Maeztu (Mdm) Unit of Excellence** seal since 2018 and it has established itself as a reference center in complex systems and an important actor in the definition of new trends in this field at national and international level.

IFISC tackles mainly theoretical but also experimental challenges situated at the dynamic intersection of complex systems and interdisciplinary applications across diverse fields including photonics, quantum physics, biology, ecology, environment, and social systems. Our research is distinguished by its integration of fundamental principles spanning network theory, statistical and nonlinear physics, stochastic processes, mathematical modeling of collective phenomena, and quantum physics. We extend our focus into complex societal contexts, exploring various facets of information technology, while actively participating in unconventional computing and learning endeavors. Moreover, our investigations delve deeply into the dynamic behaviors of life and environmental systems, underscoring the inherently interdisciplinary character of our work.

Physics approaches to interdisciplinary research in complex systems are instrumental to solving many of society's challenges. The 2021 Nobel Prize in Physics "*for providing innovative contributions to our understanding of complex physical systems*" highlighted the relevance of this field and the uniqueness of its physics methodology, making clear that complex systems modeling is key to providing understanding and forecast and also to developing practical solutions and advice for governments and policymakers. Complex systems research is key to addressing known challenges such as digitalization, health, or climate change. A healthy research base in complex systems is also necessary to be able to react to future unexpected societal changes and a principal element of a scientific preparedness strategy.

### 1.1 IFISC RESEARCH AREAS

IFISC's research is structured around four non-disjoint **research areas**: a first one developing methodologies and concepts of broad applicability, and the other three concerning the transfer of these ideas to specific **physical, biological** or **social** domains of application, thus giving us a unique opportunity to contribute to future challenges in the areas of digitalization, artificial intelligence, health, mobility or climate and environment, among others.

IFISC researchers participate in several of these research areas, based on **transversality, collaboration and interdisciplinarity**, which are IFISC's distinctive marks. IFISC's organization and structure encourages joint publications, joint participation in projects, scientific discussions and collaborations, joint supervision of PhD and master students, and cross-cutting seminars.

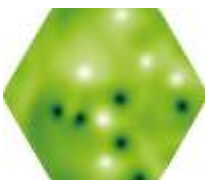
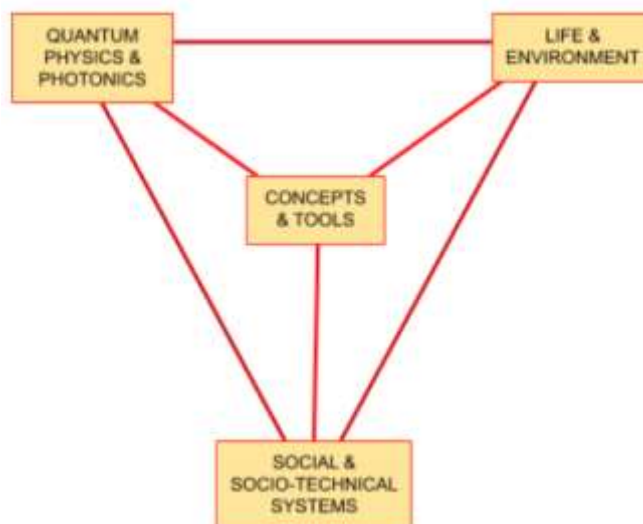

#### Concepts and Tools

*Complex systems are characterized by emergent and collective phenomena of many interacting units. Fundamental understanding of these systems and the Micro-Macro paradigm comes from a variety of disciplines and techniques which we develop and integrate: Statistical Physics, Network theory, Machine Learning and other Artificial Intelligence methods, Big Data and Data Science, Dynamical Systems, Classical and Quantum Information, Quantum thermodynamics, Information Processing methods and, in general, physics thinking for complex systems that allows tackling concepts such as Emergence, Collective Phenomena, Determinism or Stochasticity.*

*This research area is the backbone of IFISC: we develop new concepts and methods for the study of Complex Systems, and we analyze generic phenomena.*

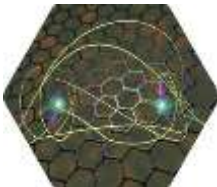

## Photonics and Quantum Systems



*In this research area, IFISC researchers have been investigating approaches based on complex systems to study processes in physical systems, mostly in quantum physics and in photonic information processing. For example, work has been done in synchronization and information transmission in quantum networks, quantum transport in nanodevices, graphene, thermoelectricity, Josephson junctions and Majorana physics in nanostructures. Quantum machine learning is also a topic of interest, which explores different learning approaches to identify a quantum advantage for data analysis.*

*Dynamical properties of photonic systems, such as lasers, optical amplifiers and fibers, have been studied in detail and used in data decoding applications for datacom and telecom. They are ideal hardware platforms for brain-inspired and neuromorphic computing, which has led to the development of novel computing concepts such as dendritic computing and folded-in-time deep neural networks and reservoir computers, heading towards more versatile and energy-efficient brain-inspired information processing and artificial intelligence..*



## Life and Environment

*Living systems and their environment are perhaps the most archetypical examples of Complex Systems. Their study involves the consideration of a huge range of time and space scales, from small biomolecules to the whole Earth, and has implications in health, conservation, and global change.*

*At IFISC, researchers have investigated genetic circuits, virus-host interactions, or microbial population dynamics, together with the different effects of noise and the statistical properties of the resulting communities. At a larger scale, different neuroscience topics, such as the role of inhibitory neurons on information processing, coding, and learning, their effects on the computational properties of cortical layers, or the impact of brain-network organization on mental diseases. Epidemics has been the focus of a number of studies, as well the use of ideas from statistical mechanics to the optimal use of medical have been also topics of interest.*

*Ecological modeling, aerial and satellite observations, and machine learning methods have allowed describing and understanding vegetation distributions on landscapes and seascapes, to detect the occurrence of plagues in plants, and to infer the evolution of seagrass meadows or coral reefs, all under the effects of global change. Animal motion has been tracked and studied. Innovative network-based methodologies have been used to characterize flow structures and transport in oceans, and their influence on the dispersion of abiotic properties and materials (temperature, microplastics), and of organic and living matter (detritus, phytoplankton). Teleconnections in the atmosphere and in the climate system have been investigated and used to anticipate weather and climate patterns associated to extreme events.*



## Social and Socio-technical systems

*We draw on our expertise in the modeling of social and socio-technical complex systems with the aim of expanding our fundamental understanding of collective effects in social systems, and of deploying digital twin technologies for realistic data-driven social simulations and its interplay with critical infrastructures. IFISC researchers have been investigating, among others: models of opinion dynamics, including non-linear interactions and aging; the relation between mobility efficiency and quality of life in cities; migration and integration of migrant communities in cities, using Big Data from ICT and online social network; understanding structure and competition processes between languages and cultural traits; or monitoring and modeling the dynamics of social networks.*

*When considering the interplay between society and infrastructures, methodologies to increase the stability and resilience of the power grid subject to demand fluctuations and analyzing the robustness of renewable-energy power grids has been a topic of interest. Air transportation has been analyzed focusing on the dynamics of delays from an information processing and macro-scale perspective, identifying correlation and causality relationships.*

## COMPUTING LAB

The Computing Services Unit manages the computational resources at IFISC. They include:

- Capabilities to perform intensive numerical calculations are provided by a High Performance Computing Cluster (HPC) integrated by 20 Atos Bull Sequana nodes mounting AMD Epyc Rome processors and 7 SIE Ladon nodes mounting AMD Epyc Turin processors for a total of 1724 cores, 16,4TB of RAM and 11 GPU computation units.
- The nodes are interconnected using a low-latency 25Gb/s communications infrastructure which is used for big data analysis and memory intensive simulations.
- Big Data storage and management is handled using a MongoDB non-relational database including a primary node with 512GB of RAM and 42 TB SSD raw storage and two replica nodes with 256GB of RAM and 40TB HD raw storage each.
- Two NFS servers summing up 216 cores and 512GB of RAM manage user's home directories with 96TB of raw storage capacity and a Data repository with 150TB of raw storage capacity.
- Private Cloud virtualization is integrated by one management node and 5 compute nodes with a total of 180 cores, 2.1TB of RAM and 100 TB of SSD raw storage.
- IFISC network is complemented with a backup server, more than 150 linux desktops, mac and windows desktops and laptops and a number of peripherals, and it is integrated to provide a transparent environment.

## PHOTONICS LAB



Since 2009 a Photonics Laboratory of highest standards has been established. The lab is equipped with a Faraday cage for electromagnetic shielding and houses several experiments of delay-coupled lasers and laser arrays, optoelectronic systems, as well as photonic information processing systems using the latest technology to characterize the optical emission with multi-Gigahertz bandwidth: in the temporal domain via fast detectors and 40 GHz analog bandwidth real-time oscilloscope, and in the spectral domain via a 44 GHz signal and spectrum analyzer. In addition, high-resolution optical characterization can be performed via heterodyne techniques and different spectrometers. Finally, optical and electrical laser modulation can be implemented with arbitrary waveforms up to 92 GigaSamples/second.

## 1.2 “MARIA DE MAEZTU” EXCELLENCE AWARD

In 2018, **IFISC** was awarded the “**Unidad de Excelencia María de Maeztu**” distinction, for the period 2018-2022, entering the selective **SOMMa Alliance**. This distinction was renewed for the period 2023-2026 underscoring the outstanding achievements of IFISC during the years 2018-2022. The award is granted by the Agencia Estatal de Investigación (AEI), belonging to the Ministry of Science, Innovation and Universities, after a highly selective process and a thorough evaluation according to the highest standards by an international panel.

According to the Ministry, being awarded as “Severo Ochoa” or “María de Maeztu” represents “the recognition and accreditation of the best centers and units that stand out for their international impact and the relevance of their results obtained in the last four years”. Moreover, it targets “the financing of strategic research programmes with the aim of consolidating their scientific capacities and contributing to their international leadership”.

All distinguished centers and units excel due to the global resonance of their scientific contributions, their commitment to postgraduate teaching, their innovation prowess, and their robust engagement with the social and economic spheres. They are categorized as world-class entities with highly competitive frontier research programs that are capable of attracting international talent.

The units that have been selected in the “Maria de Maeztu” (MdM) category, like IFISC, receive a total funding of 2,000,000 Euros during four years plus six pre-doctoral contracts as well as access to funding sources restricted to the units of excellence.

This award consolidated IFISC as a reference institute in the research field of complex systems and allowed a growth of more than 40% in personnel with respect to 2018. **IFISC was the first institute in the Balearic Islands receiving the Maria de Maeztu award.**

The research project associated to the MdM award covers the activities of the entire institute defining a strategic plan and focusing the research effort for the period 2023 – 2026. The following scheme summarizes the research lines on which the Maria de Maeztu award focusses:

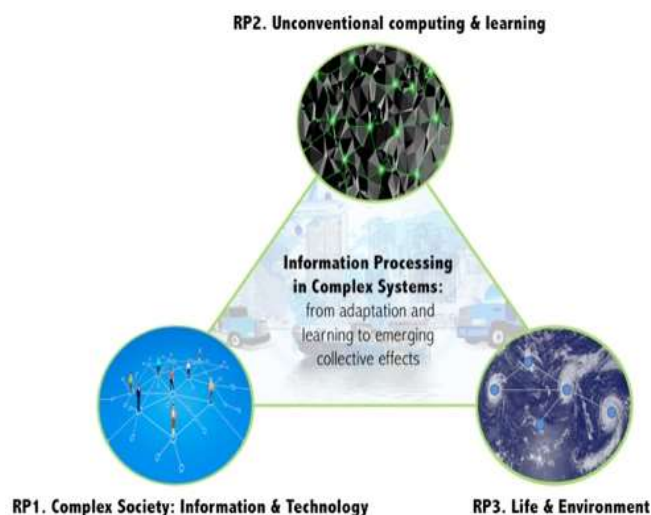

Our present MdM project endeavors to conduct strategic research in information processing within complex systems, emphasizing novel dimensions of adaptation, learning, and emergent collective effects. This initiative is structured around three intricately intertwined research pillars (illustrated in the figure above), which are designed to tackle contemporary societal challenges while aligning closely with EU priorities. These pillars encompass:

RP1. Complex society: information & technology

RP2. Unconventional computing & learning

RP3. Life & environmental dynamics

### IFISC – MdM PERSONNEL



All IFISC researchers actively contribute to the MdM scientific program, underscoring the institute's commitment to fostering a collaborative environment that thrives on diversity, interactions, and scientific dialogue. Personnel who have been recruited during 2025:

#### Postdoctoral Researchers:

Lluís Arola  
Sreetama Das  
Giampaolo Folena  
Catharina E. Graafland  
Jaume Ojer  
Nathan Silvano

# 1

## PRESENTATION AND RESEARCH AREAS

### PhD Students:

Miguel Álvarez  
Gorka Buenvarón  
Annalisa Caligiuri  
Antonio Coll de San Simón  
Paride Crisafulli  
Fernando Diaz  
Juan A. García Castillo  
Pedro Jiménez  
Adrià Labay  
Jesús A. Moreno  
Carlotta Nunzi  
Pablo Rosillo Rodes  
Ivan Sevostianov

### Project Manager:

Simona Obreja

### Communication and dissemination:

Adrian García Candel

### Technician

David Jiménez

### Administration support

Alberto J. Sánchez

1.3. IFISC SERVICE UNIT: DataAnalytics@IFISC



**Solutions based on Big Data for**

- \* Social Sciences
- \* Ecology
- \* Biomedicine

Relying on the experience gained in research projects and contracts with companies, IFISC has created **DataAnalytics@IFISC** as a **service unit** devoted to data mining and big data analysis.

IFISC know-how includes analysis of data from social networks, mobile phone and credit card records, transport networks at the urban scale, air transport, census and surveys, electoral results in the space, electrocardiograms, electro and magneto encephalograms, marine currents and animal populations. Previous results include works on population levels, mobility, transport and tourism, land use, economic inequalities in urban areas, epidemic spreading, delay propagation in air transportation, heart arrhythmia and encephalogram series analysis using machine learning, hospital emergency demand, and marine megafauna migrations and spatial connectivity studied with satellite data.

Data Analytics@IFISC provides solutions to CSIC, UIB and external entities based on big data for computational social sciences, ecology and biomedicine, including:

- Sampling from our databases and the preparation of reports based on aggregated data.
- Development of new analysis methods ad hoc including machine learning techniques.
- Consulting on social, economic and technical questions through Big Data analytics.

\*IFISC also participates together with other UIB researchers in the UIB Innovation Unit “Data Analytics@IFISC\_UIB”.



## 1.4 IFISC STRUCTURE CHART



1.5 2025 REPRESENTATIVE RESEARCH RESULTS

Here are some research results published during 2024. They are representative of the different research lines and thus illustrate the range of topics studied at IFISC.

**Global tracking of marine megafauna space use reveals how to achieve conservation targets**

*Sequeira, A.M.M.; Eguíluz, V.M.; et al.*

Science 388, 1086-1097

Understanding how highly mobile species use space is a fundamental challenge in ecology, with direct implications for global conservation policies. In this work, we adopt a complex systems perspective to address this problem, combining large-scale data integration, movement ecology, and spatial optimization to uncover the collective patterns underlying marine megafauna dynamics.

We assembled an unprecedented global dataset of animal movements, comprising millions of geolocated observations across more than one hundred species, including sharks, whales, seabirds, and turtles. By analyzing these trajectories as emergent patterns of a multi-species system, we identify key regions of the ocean that concentrate essential behaviors such as migration and residency. These “important marine megafauna areas” emerge not from static distributions, but from the dynamical organization of movement, revealing a structured yet highly heterogeneous use of space at the planetary scale.

Our results show that a relatively small fraction of the ocean hosts the majority of ecological activity, reflecting a strong spatial concentration. However, this organization poses a major challenge for conservation. We find that current and planned protection targets—such as the global goal of safeguarding 30% of the ocean—are insufficient to cover these critical areas, leaving a large proportion of biologically relevant regions exposed to human pressures.

By integrating global maps of anthropogenic threats, including fishing, shipping, climate change, and pollution, we demonstrate that most of these key areas are simultaneously subject to multiple stressors. This overlap highlights the need to move beyond static, area-based conservation strategies toward a more dynamic and systemic approach. In particular, our work shows that effective conservation of mobile species requires coupling protected areas with adaptive management measures that account for movement, connectivity, and cross-scale interactions.

This study illustrates how tools from complex systems—such as the analysis of collective patterns, multi-layer data integration, and optimization—can provide new insights into biodiversity conservation. By revealing the mismatch between ecological dynamics and current policy targets, it contributes to bridging the gap between fundamental science and global sustainability challenges.

**Figure 1: Global space use of marine megafauna and important megafauna areas.** (Left) Map of detected migratory corridors, residence areas, and both corridors and residencies across taxa. Gray indicates grid cells where tracking data were available but no specific behavior was identified for any taxon. Light blue areas depict regions where we did not have tracking data. (Right) Increase in area protection to 30% will leave ~60% of important megafauna areas exposed to major anthropogenic threats. Map showing how much the increase in MPAs from the current 8% (purple) to 30% (green) would cover from our prioritization from movement data.

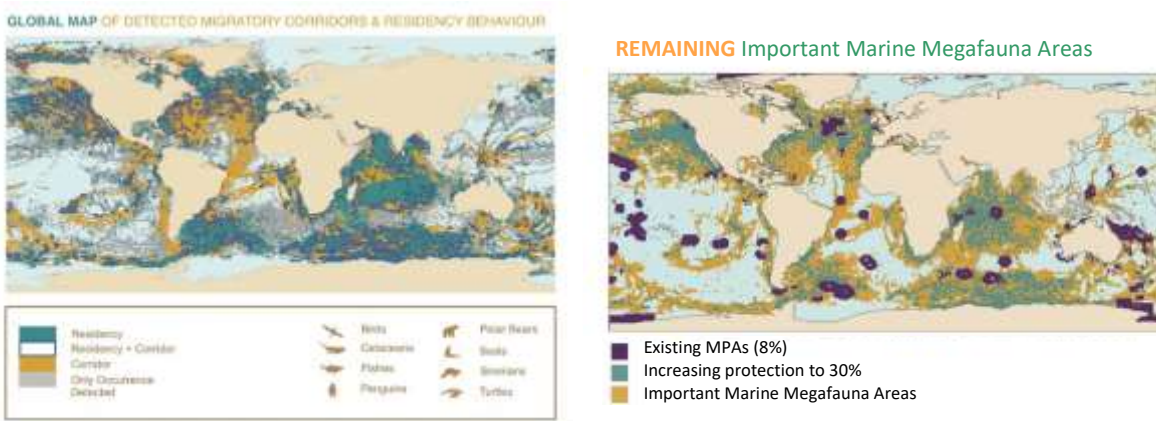

## How spatiotemporal dynamics can enhance ecosystem resilience

Moreno-Spiegelberg, Pablo; Rietkerk, Max; Gomila, Damià

Proceedings of the National Academy of Sciences of the USA, 122, e2412522122

Researchers at **IFISC (UIB-CSIC)** have uncovered a hidden survival strategy in Mediterranean *Posidonia oceanica* meadows. As these plants grow, they produce organic matter that decomposes into **sulfides**, toxins that accumulate in the soil and, under adverse conditions, can trigger a sudden ecosystem collapse. However, the study shows that instead of dying off, meadows can "flee" these toxins by self-organizing into complex, **traveling patterns**.

By forming moving structures—such as **spirals, wave trains, and expanding rings**—the plants continuously colonize fresh soil while leaving toxic areas behind to recover. This "dance" allows the meadow to maintain higher biomass and survive environmental stressors, like **rising sea temperatures**, that would otherwise cause total extinction. Effectively, movement acts as a shield, pushing the ecosystem's ultimate tipping point much further than a stationary meadow could endure.

One of the study's most striking results is that these patterns follow a **predictable sequence** as stress increases. By comparing mathematical simulations with high-resolution drone and satellite imagery, the researchers found a near-perfect match (Figure 1). This suggests that the shape of a meadow seen from above can serve as a **"diagnostic tool"** to predict its proximity to collapse. These findings provide a powerful new perspective for conservation, demonstrating how the "patterns of life" are often signs of a heroic struggle for resilience.

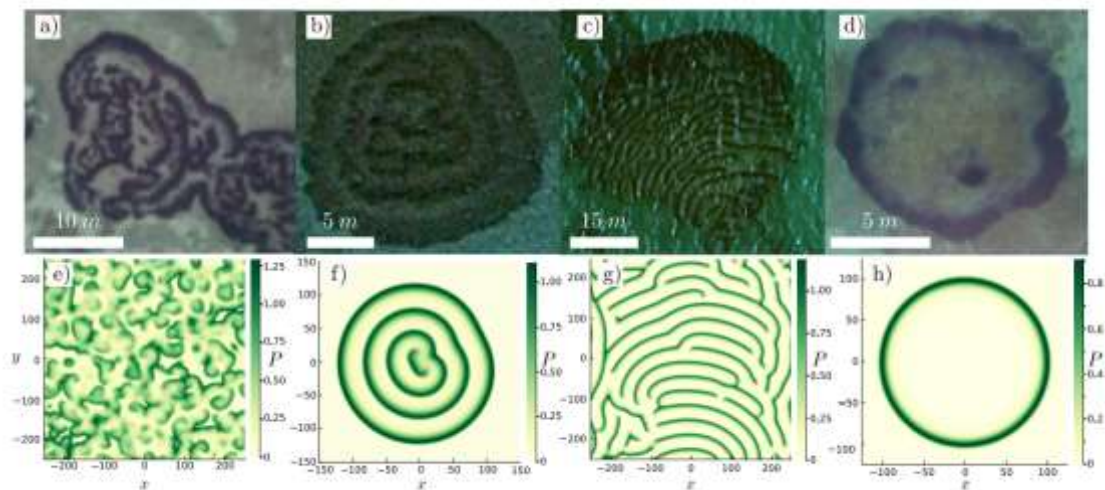

**Figure 1. Nature vs. Model.** A comparison of real-world aerial images of *Posidonia oceanica* (A–D) with the team's numerical simulations (E–H). The patterns—from turbulent states to expanding rings—capture the meadow's transition under increasing stress.

## Gambling Carnot Engine

Tohme, Tarek; Bedoya, V.; di Bello, C.; Bresque, L.; Manzano, G.; Roldán, E.  
Physical Review Letters, 067101

A central goal for statistical physics in the XXI century is the search for efficient protocols of energy harvesting from the fluctuations of small systems. So far, the combination of theory and experiments in stochastic thermodynamics have led to two key research programs along efficient energy extraction: (i) mimicking classical engines with miniaturized analogs (e.g., stochastic heat engines), and (ii) exploiting information processing through feedback control protocols (e.g., Maxwell's demons).

In this work, inspired by previous experimental research on Brownian engines implemented with colloidal particles in optical traps, and theoretical insights about the impact of gambling strategies on thermodynamic processes, we introduce an experimentally realizable feedback protocol denoted as the “gambling Carnot engine” (GCE). This engine, by mixing elements from stochastic thermal machines and feedback control based on the information retrieved from the engine dynamical evolution, is able to fully convert cyclically the net heat absorbed from a hot bath into work extracted on the cycle, hence beating traditional thermodynamic limits.

The feedback protocol is rather simple: it executes a sudden quench at zero work cost when the particle position satisfies a specific first-passage condition. As a result, the engine enhances both power and efficiency with respect to a standard Carnot cycle, surpassing Carnot's efficiency at maximum power. Using first-passage and martingale theory, we derive analytical expressions for the power and efficiency far beyond the quasistatic limit and provide scaling arguments for their dependency with the cycle duration. Numerical simulations are in perfect agreement with our theoretical findings, and illustrate the impact of the data acquisition rate on the engine's performance.

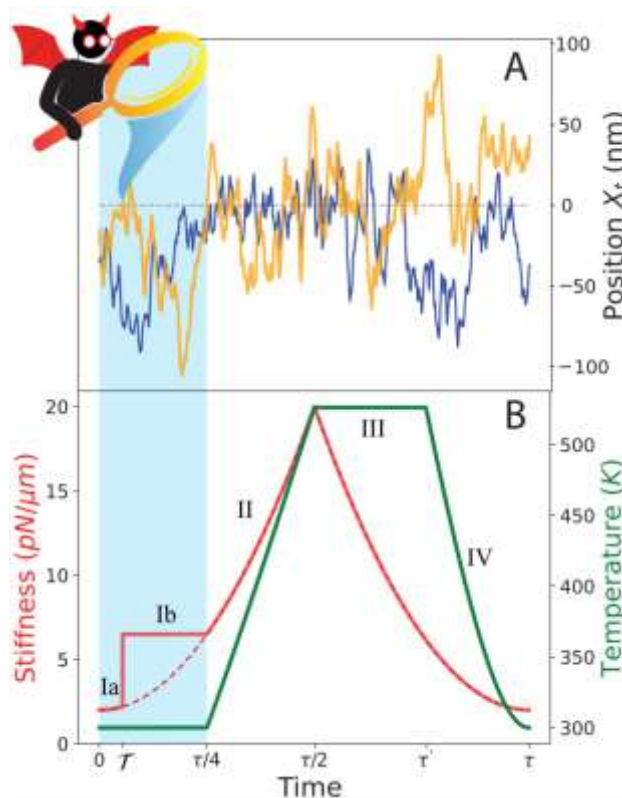

**FIG.1** (A) Sketch of a gambling Carnot engine (GCE) at work together with its driving protocol (B) along a cycle of duration  $\tau$ . A demon monitors the fluctuating position of an underdamped, trapped Brownian particle [panel (a)] during isothermal compression (blue light square) following the stochastic feedback protocol in panel (B). If the particle first crosses the origin at a stochastic time  $T < \tau/4$  [orange trajectory in panel (A)], the stiffness is switched suddenly at time  $T$  to  $\kappa \tau/4$  [continuous red line in panel (b)]. On the other hand, if the particle does not cross the origin before  $\tau/4$  [blue trajectory in panel (A)], the stiffness follows the deterministic protocol from the experimentally realized Brownian Carnot engine (BCE) [dashed red line in panel (B)].

### NAc-DBS selectively enhances memory updating without effect on retrieval

Pérez-Segura, A.; Medina, J.; Cedán Cerdá, A.; Sánchez Ferri, C.; Torres, D.; Mirasso, C.; Strange, B.; M. Eguíluz, V.; Lacasa, L.; Canals, S.  
Neuropsychopharmacology 50:1420–1429

Deep brain stimulation (DBS) of the Nucleus Accumbens (NAc) is used for treatment-resistant psychiatric disorders, but its cognitive effects remain poorly understood. To examine its impact on spatial memory in rats, researchers designed a modified Morris Water Maze in which rats navigated a circular arena to find a virtual platform. Locating the target dimmed the lights and allowed the rat to escape (see Figure 1).

The experiment spanned three consecutive days (S1–S3), each consisting of four trials (T1–T4). DBS was optionally delivered during S2. Because the target location changed daily, the team was able to isolate two distinct memory processes: **short-term memory (STM)**, measured by how efficiently rats refined their search for the current target within a single day (T1 to T4); and **long-term memory (LTM)**, measured by the rats' tendency to revisit the previous day's target during the first session of a new day. Additionally, because DBS was applied during S2, researchers could assess its influence on both LTM **encoding**—the storage of new information—and **retrieval**, the ability to access stored memories.

Through a high-dimensional behavioral analysis across 20 metrics, the team determined that NAc-DBS significantly enhanced memory encoding, resulting in higher LTM performance on the day following stimulation (S3). Concurrent functional magnetic

resonance imaging (fMRI) revealed that NAc-DBS induced functional reorganization within the mesocorticolimbic system, leading to sustained increases in activity in regions critical for memory formation. Notably, the treatment did not affect STM or LTM retrieval, and no motor or stress-related side effects were detected.

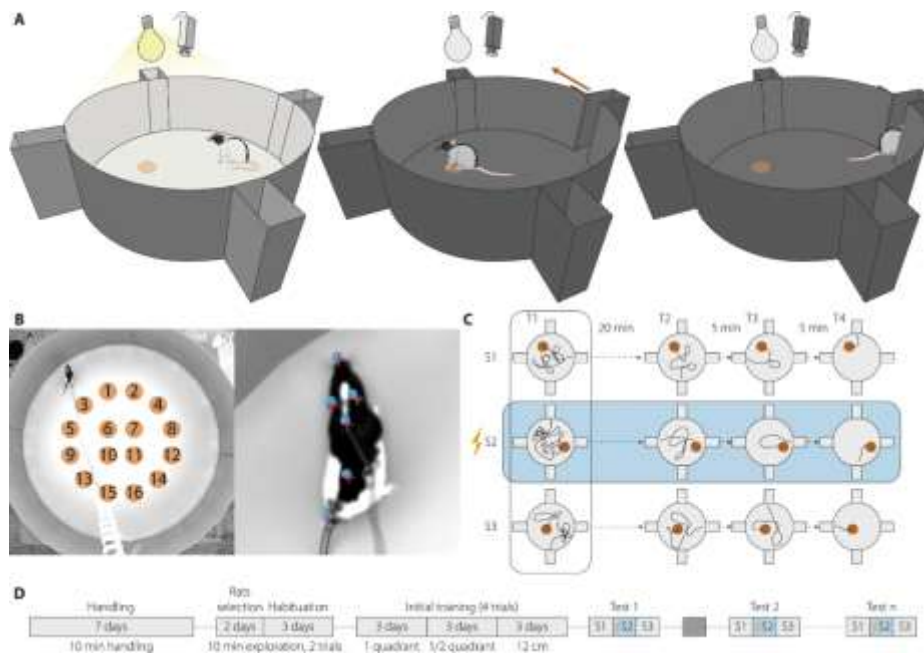

**Experimental design.** **A** A 180-cm circular arena with four entry boxes is brightly lit. Rats search for a invisible virtual platform (orange circle). When they reach it, illumination dims and the exit door opens, allowing return to the entry box. **B** The 16 possible virtual platform locations and labeled tracking points on the rat. **C** Memory testing includes four trials (T1–T4) across three consecutive days (S1–S3), with pseudo-random platform locations. NAc-DBS can be optionally applied in S2. **D** Training schedule.

### Unravelling the universal spatial properties of coral reefs

Giménez-Romero, A.; Matías, M.A.; Duarte, C.M.  
 Global Ecology and Biogeography 34, e13939

Coral reefs are among Earth’s largest and most intricate living systems, acting as natural barriers that protect coastlines and support immense marine biodiversity. Despite their variety—from circular atolls to long barrier reefs—in this work we uncover the universal mathematical rules that govern how reefs form and grow worldwide. This study uses data from the Allen Coral Atlas, which combines satellite imagery and machine learning, leading to the identification of 1.58 million individual reefs covering over 52,000 square kilometers. Most are small (median size 0.3 hectares), though some expand to nearly 100 square kilometers.

The study revealed that coral reefs obey three universal scaling laws, consistent across all regions and environments:

- Size: Reef sizes follow a power-law distribution, with countless small reefs and few very large ones.
- Spacing: Reefs cluster within 10–100 meters of each other, rarely existing in isolation.
- Shape: A predictable relationship (exponent 1.26) links a reef’s area and perimeter, showing their fractal geometry.

These fractal patterns mean reefs look similar whether viewed by satellite or up close. As reefs grow, they evolve from compact, rounded shapes into more complex, elongated structures with inner lagoons or holes.

This discovery provides a global mathematical baseline for reef health—a blueprint that could guide conservation and restoration efforts under frameworks like the Kunming-Montreal Biodiversity Agreement, helping scientists design projects that replicate the geometric harmony of thriving reefs.

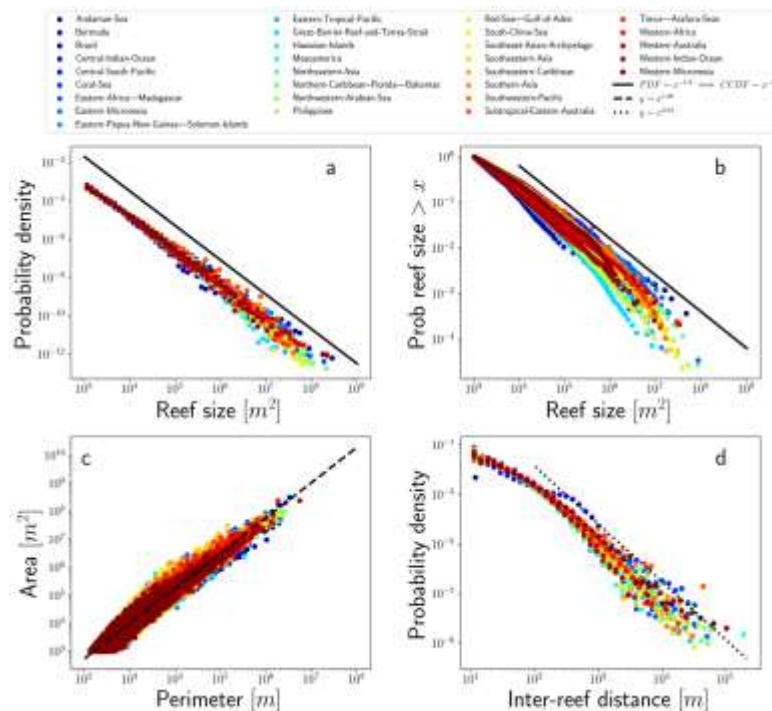

Fig.1 Macroecological patterns of global coral reef size, geometry and coral spacing.

### Environmental Flows and Pattern Formation in Nonlocal Ecological Systems

#### Flow spatial structure determines pattern instabilities in nonlocal models of population dynamics

Silvano, Nathan O.; Valeriano, João; Hernández-García, Emilio; López, Cristóbal; Martínez-García, Ricardo, Communications Physics 8, 326 (1-12)

Spatial pattern formation driven by long-range competition is analyzed using a nonlocal Fisher–Kolmogorov type model coupled to environmental flows. Two prototypical velocity fields are considered: a sinusoidal shear flow and a Rankine vortex. In the absence of flow, the system develops stationary hexagonal patterns that maximize population abundance. Advection strongly alters both spatial organization and population dynamics. In the sinusoidal flow, coherent transport of population clusters induces periodic oscillations in total abundance, with a frequency determined by the flow kinematics. Increasing flow intensity progressively distorts the patterns modifying this periodic behavior. In contrast, the vortex flow produces more complex dynamics, including rotating structures, ring formation, and merging and fragmentation of clusters, often leading to irregular or chaotic temporal evolution. A key result is the systematic decrease in mean population abundance with increasing flow strength, reflecting the disruption of spatial structures that minimize competition. These findings highlight the strong coupling between environmental transport and ecological self-organization.

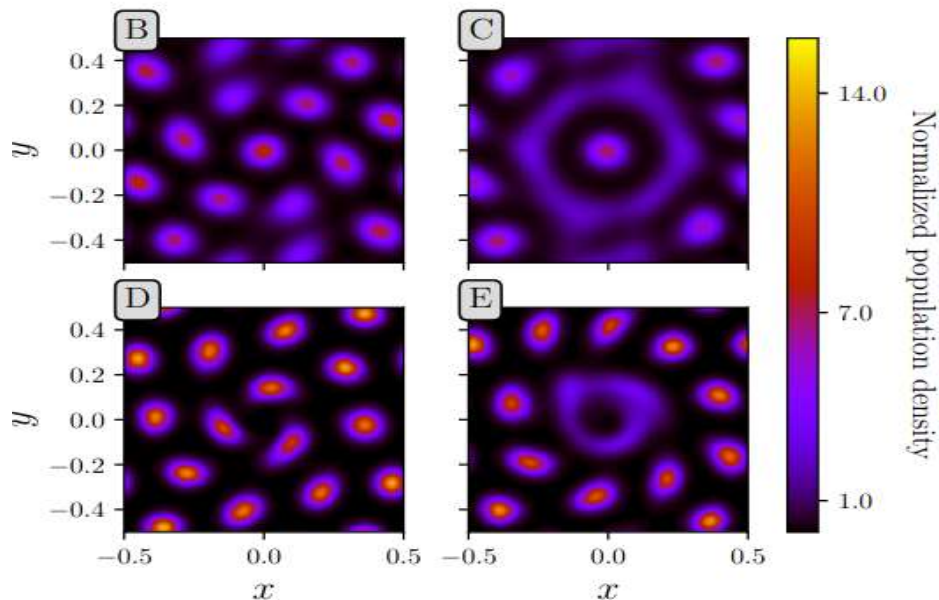

Figure: Spatial patterns in the vortex flow, illustrating rotations, ring structures, and dynamic reorganization of clusters.

## Mapping and modeling age-related changes in intrinsic neural timescales

Kaichao Wu, Kaichao; L. Gollo, Leonardo

Communication Biology, 2025; 8(1), 167

As the days go by, our brains are constantly changing. Synapses evolve over time, and our entire brain ages. The accumulation of these age-related factors also changes how the brain processes information over time, and these changes can affect how we think, remember, and make decisions.

In our study, we show that spontaneous brain activity fades more quickly with age. This shift may limit memory and reduce our ability to perform tasks that require sustained information processing or fine discrimination.

By combining brain imaging with computational modeling, we integrate these changes in brain structure, brain activity, and cognitive function into a single, coherent framework. We find that aging is associated with a shift away from a special operating critical mode that enhances information processing. In younger brains, activity tends to persist longer, allowing different regions to interact more effectively and sustain richer patterns of activity. As the brain ages and undergoes structural deterioration, this delicate balance is disrupted. Activity becomes more short-lived, less coordinated, and less capable of integrating information over time, which is a process that is essential for many core brain functions.

Figure 1. Intrinsic timescales and critical dynamics in empirical and modeled neural activity.

**A.** Lag-1 autocorrelation (AC1) of empirical fMRI BOLD time series (top) and simulated neuronal network activity (bottom). **B.** AC1 as a function of the branching ratio ( $\sigma$ ), peaking at the critical point ( $\sigma_c = 1$ ). **C.** Intrinsic timescales also peak at criticality ( $\sigma_c = 1$ ). Advancing age (yellow arrow) shifts the neuronal network towards a more subcritical regime ( $\sigma < 1$ ), resulting in reduced temporal integration. Inset: The neuronal network exhibits a phase transition at  $\sigma_c = 1$ , separating subcritical ( $\sigma < 1$ ) and supercritical ( $\sigma > 1$ ) regimes. Network activity is averaged across 100 trials.

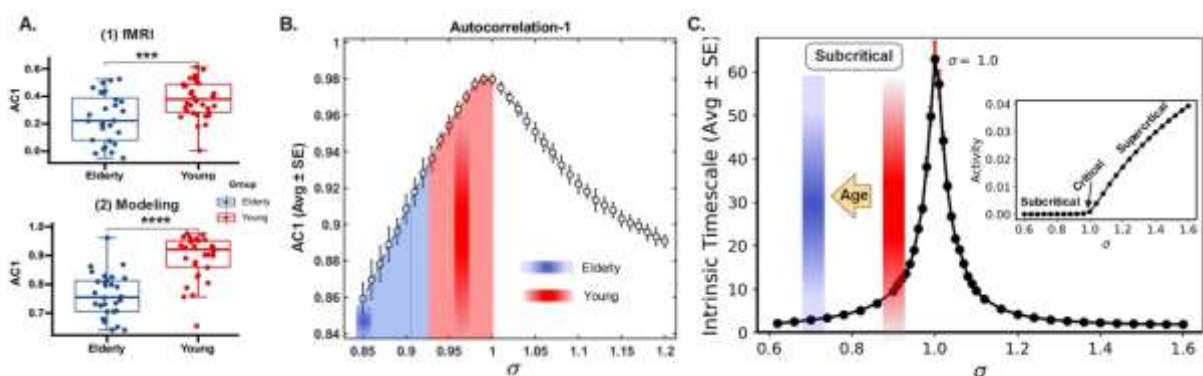

## Quantum machine learning via continuous-variable cluster states and teleportation

García-Beni, Jorge, et al

EPJ Quantum Technology 12.1: 63.

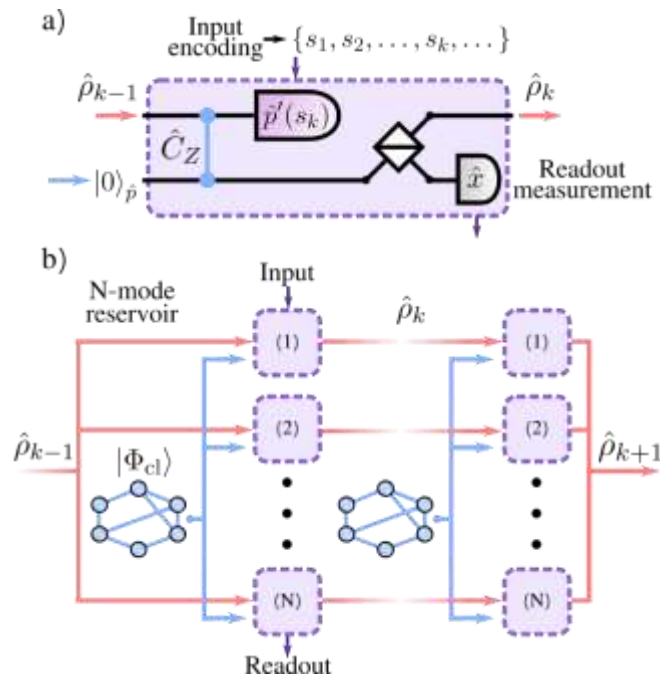

From financial markets to climate data or brain activity, many real-world problems depend on recognizing patterns that can evolve over time. Reservoir computing is a machine learning paradigm that exploits the dynamics of an artificial network (the reservoir) with minimal learning requirements to reconstruct such signals. Unlike conventional neural networks, it avoids the computational cost of optimizing internal weights since only the output layer is trained, via linear regression. Quantum reservoir computing (QRC) uses quantum systems as reservoirs. Photonic platforms are promising in this context, as they offer entanglement and squeezing as resources, while remaining scalable and operable at room temperature.

Here, we propose for the first time a measurement-based quantum reservoir computing protocol exhibiting memory and taking advantage of continuous variable cluster states. These states are key to several photonic quantum technologies, enabling universal quantum computing as well as quantum communication protocols. In this design, measurements enable input injections, information processing and continuous monitoring for time series processing. The architecture's power and versatility are tested by performing a set of benchmark tasks showing that the protocol displays internal memory and is suitable for both static and temporal information processing without hardware modifications.

### Complete aging in the noisy voter model enhances consensus formation

Llabrés, Jaume; Oliver-Bonafoux, Sara; Anteneodo, Celia; Toral, Raúl

Chaos, Solitons and Fractals **194**, 116153

Collective opinion formation can be studied using simple agent-based models in which individuals update their opinions either by copying others (social influence) or by making random independent changes. The balance between these two mechanisms determines whether a population reaches consensus or remains divided.

This work investigates the role of **aging** (defined as the time  $\tau$  a person has spent in a particular opinion state) in the noisy voter model. Aging introduces a memory mechanism whereby individuals become less likely to change their opinion the longer they hold it. While previous studies considered **partial aging**, where memory affects only the copying (social influence) mechanism, we instead study **complete aging**, where memory also affects the idiosyncratic random changes.

Using analytical mean-field theory together with large-scale simulations, we show that while partial aging already modifies the transition between consensus and disorder, complete aging significantly enlarges the region where consensus emerges. In particular, it shifts the critical point  $a_c$  to higher values compared with the partial aging case and produces a stronger asymmetry in the average aging times of opposing opinions. In both cases, moderate aging promotes agreement, whereas very strong aging can hinder coordination because agents become too reluctant to change their opinion. Consequently, consensus is maximized at an intermediate aging strength. However, when the aging probability decays asymptotically to zero for large  $\tau$ , a steady state may not be reached for complete aging, unlike in the partial aging scenario.

These results highlight how memory effects can reshape collective social dynamics.

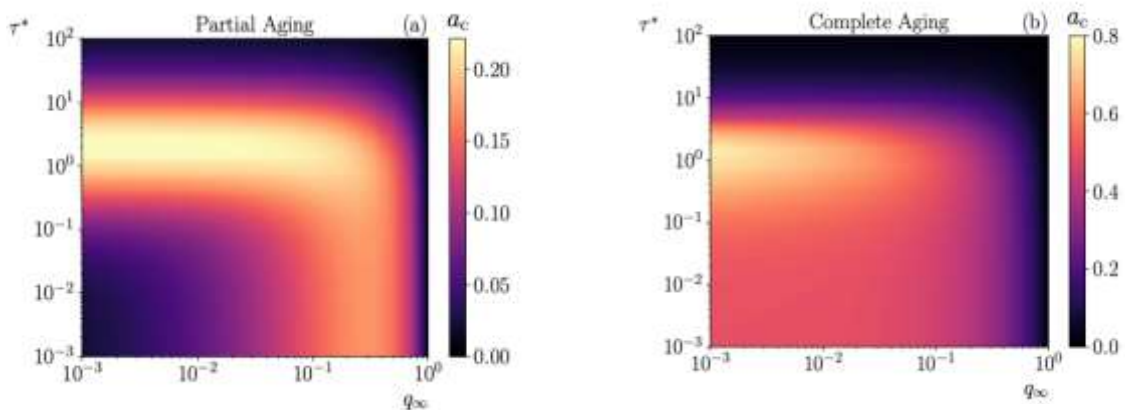

Heat map of the critical noise value  $a_c$  in the parameter space  $(q_\infty, \tau^*)$ , where  $q_\infty$  is the asymptotic activation probability and  $\tau^*$  the characteristic decay time of the aging kernel. Panel (a) shows the case of **partial aging**, while panel (b) corresponds to **complete aging**. Note that the critical values  $a_c$  are significantly larger in the complete aging case, indicating an enlarged region where consensus can emerge.

## Entropy and Type-Token Ratio in Gigaword Corpora

Rosillo-Rodes, Pablo; San Miguel, Maxi; Sanchez, David

Physical Review Research 7, 013145 (1-14)

The diversity of many complex systems can be analyzed by describing the richness of the classes that compose them (such as species in ecology) and the number of members (individuals) that make up those classes. In linguistics, this distinction is framed through the relationship between **types** (unique words in a vocabulary) and **tokens** (the total number of those words in a text). Lexical diversity is typically characterized by two metrics: the **type-token ratio (TTR)**, which measures the proportion of unique words to total tokens, and **word entropy (H)**, which captures the distribution and uniformity of those words.

In this work, we conduct an analysis of six massive **corpora** spanning English, Spanish, and Turkish. These datasets are referred to as “gigaword” because they comprise billions of words sourced from extensive news archives, web crawls and IFISC’s Twitter database. Our study reveals a consistent **empirical functional relation** between entropy and TTR that remains robust across different languages, genres, and registers.

To understand this observed empirical relation we derive an **asymptotic relation** of the text entropy for large corpora. While the former represents the direct pattern found in the data, the latter is grounded in the fundamental statistical laws of natural language: **Zipf’s law** (regarding word frequency) and **Heaps’ law** (concerning vocabulary growth). These laws act as statistical approximations of observed linguistic patterns. Our findings demonstrate that the theoretical law coincides with the empirical data in the limit of **low TTR**, which is the relevant regime for large-scale corpora. While language morphology influences specific values, with agglutinative languages like Turkish exhibiting higher entropy, the overall functional dependence provides a useful tool for evaluating information content and lexical richness in massive linguistic datasets and possibly many other complex systems.

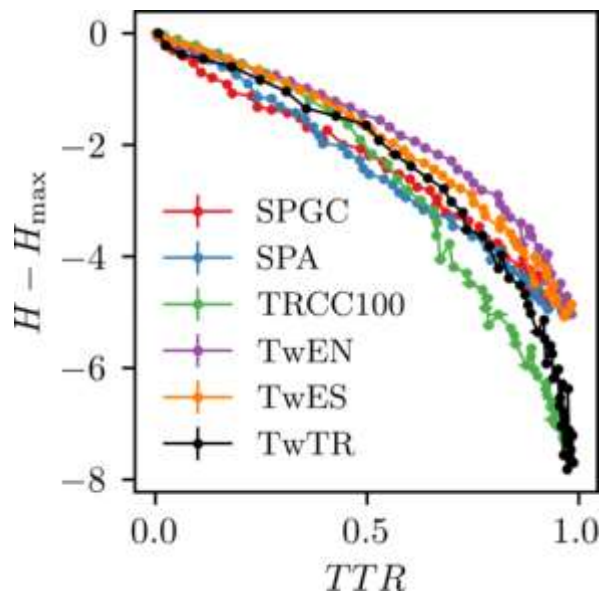

**Figure 1: Functional relationship between entropy and TTR**

Empirical relationship between word entropy (H) and the type-token ratio (TTR) across six massive linguistic datasets. The data points represent the empirical values obtained from English, Spanish, and Turkish Gigaword corpora.  $H_{max}$  represents the maximum measured entropy for a given corpora.

## Entanglement Generation and Stabilization by Coherent Collisions

A. Bozkurt, Mert; López, R.; Ryu, S.

Phys. Rev. Res. 7, 013145

This work demonstrates that repeated coherent collisions mediated by itinerant electrons can be used to generate and stabilize entanglement between two distant spin qubits. The authors develop a generic collisional framework in which successive electron-qubit interactions, combined with suitable local driving fields, drive the system toward an entangled steady state. In the symmetric collision regime, the steady state becomes unique and approaches maximal entanglement.

A notable feature of the mechanism is its dissipative character, which makes the resulting entanglement robust against environmental decoherence provided that collisions occur sufficiently frequently. The study thus establishes coherent collisions as an efficient tool for nonlocal quantum-state engineering. Since the proposed setup can be implemented using single-electron sources in chiral conductors, the results open a realistic route toward the controlled generation of stable entanglement in mesoscopic quantum platforms.

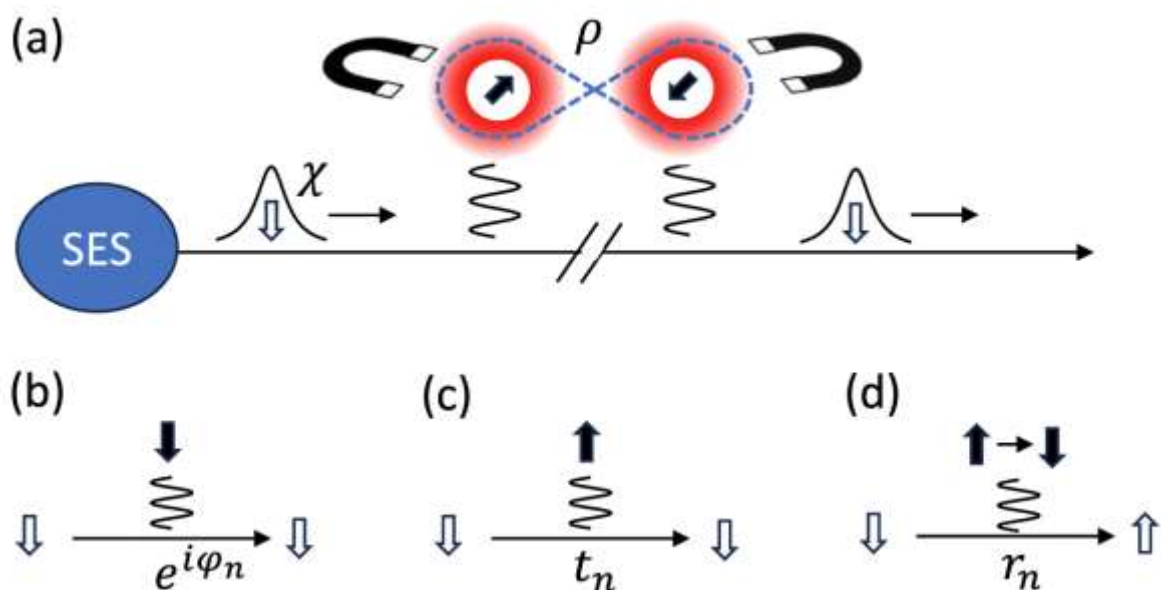

### Breaking coexistence: Zealotry vs nonlinear social impact

Kitching, Christopher R.; Ramirez, Lucía S.; San Miguel, Maxi; Galla, Tobias  
Chaos **35**, 083133

This is a contribution to the field of modelling opinion dynamics and evolutionary game theory. Models of opinion dynamics describe a population or network of “free” agents who are able to change opinion on an issue. One simple mechanism for change is imitation – one agent copies the opinion of another. In more complex settings, change of an agent becomes more likely if they interact with a group of other individuals who all share an opposing opinion. This is known as “social impact”. Latané showed from empirical data that the influence of a group depends on its size  $N$  as  $N^q$ , where  $q$  is a social-impact exponent. Interestingly, Latané finds that this exponent is often smaller than one ( $0 < q < 1$ ) [1]. In nonlinear voter models such sub-linear impact is known to promote coexistence of multiple opinions. Supra-linear impact ( $q > 1$ ) on the other hand favours consensus.

Our main focus in this paper is the on the combination of nonlinear social impact, and zealotry. Zealots are agents who have a fixed opinion, and never change. Free agents are influenced by zealots and by other free agents. For one-sided zealotry (i.e., all zealots are of the same opinion) the only stable state is consensus at that opinion. If there are zealots of more than one opinion the situation is more complicated, and either consensus or coexistence can be stable.

Phase portrait of a partisan voter model with zealotry.

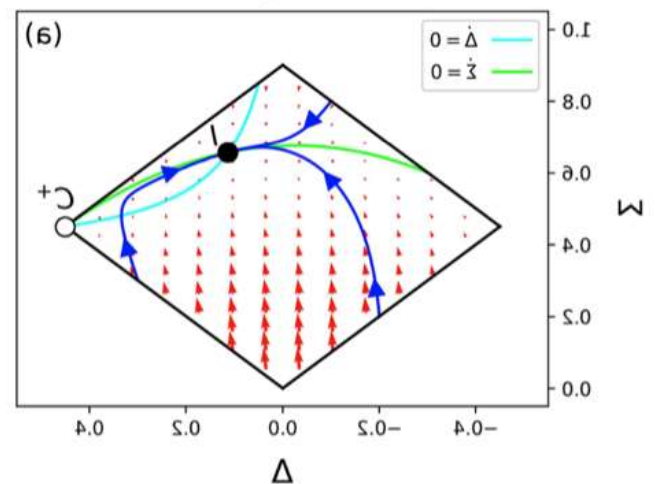

In this paper we carry out a detailed analysis of the combined effects of zealotry and non-linear social impact. We do this for the (nonlinear) voter model, for the so-called partisan voter model [2], and for evolutionary games. In particular we ask if there is a critical level of (one-sided) zealotry that can break the coexistence of multiple opinions (or strategies in games), and hence enforce consensus. Our main conclusion is that sub-linear social impact ( $q < 1$ ) can counter the effects of zealotry: if the social impact function is sub-linear no level of zealotry can enforce consensus in the models that we studied.

For sub-linear social impact, the probability of adopting a state of low prevalence is higher than in a model in which agents imitate a randomly chosen interaction partner (linear impact). This means that, for  $q < 1$ , small minorities can have sufficient impact to prevent the formation of consensus on the state promoted by the zealots, even if there is a large majority for that state among the population of free agents.

[1] B. Latané, Am. Psychol. **36**, 343 (1981).

[2] J. Llabrés, M. San Miguel, and R. Toral, Phys. Rev. E **108**, 054106 (2023).

## Speedup of an all-optical delay-based reservoir computer via input rate increase and bandwidth enhancement

Goldmann, Mirko; Estébanez, Irene; Mirasso, Claudio; Fischer, Ingo; Argyris, Apostolos; C. Soriano, Miguel  
Chaos 35, 073131

Reservoir computing (RC) is a powerful brain-inspired machine learning technique, with the corresponding physical implementations offering potential advantages in speed and energy efficiency over traditional methods. While photonic implementations of RC offer potential advantages in speed and energy efficiency, building large networks of physically interconnected nonlinear nodes is technically challenging. Delay-based reservoir computing (DBRC) provides an elegant solution by utilizing a single nonlinear element, such as a semiconductor laser with optical feedback, to generate a series of "virtual nodes" through time-multiplexing.

This work demonstrates the acceleration and optimization of an all-optical delay-based RC designed for high-speed time-series prediction. The system utilizes a single nonlinear element, a semiconductor laser with delayed optical feedback, driven by an injection laser that provides time-multiplexed input signals. A critical technical advancement presented is the exploitation of bandwidth enhancement, which allows for a virtual node separation as small as 12 ps. By decoupling the input processing rate from the system's intrinsic delay time, the researchers investigated how to optimize the number of virtual nodes to match the specific memory requirements of a given task. Numerical simulations using the Lang-Kobayashi rate equations were used to guide experimental realizations, showing that processing at rates significantly faster than the feedback delay can lead to superior performance. The results reveal a substantial leap in both computational throughput and energy efficiency, achieving an inference rate of 0.417 GSa/s, which represents a tenfold improvement over traditional processing at the rate of the delay time. This speedup directly translates to a more sustainable architecture, reducing energy consumption from 26.5 nJ to 2.6 nJ per inference in proof-of-concept settings. The system was successfully benchmarked using the chaotic Mackey-Glass and the experimental Santa Fe time-series tasks, highlighting that optimal performance requires tuning the physical substrate's time scales to the statistical properties of the data. In Fig. 1, it is shown that the prediction error of a Mackey-Glass task reduces with increasing feedback strength (reduced feedback attenuation). Additionally, the prediction error is especially low in a small region of the frequency detuning, which we indicate as the region of partial locking between the driving and response laser. Both numerical and experimental evaluations underscore the importance of appropriately calibrating the feedback strength and the frequency detuning to achieve high performance and ultrafast time-series prediction. Ultimately, the study underscores that the alignment of internal physical time scales with task-required conditions is essential for developing next-generation, ultra-fast, and energy-efficient analog photonic computing.

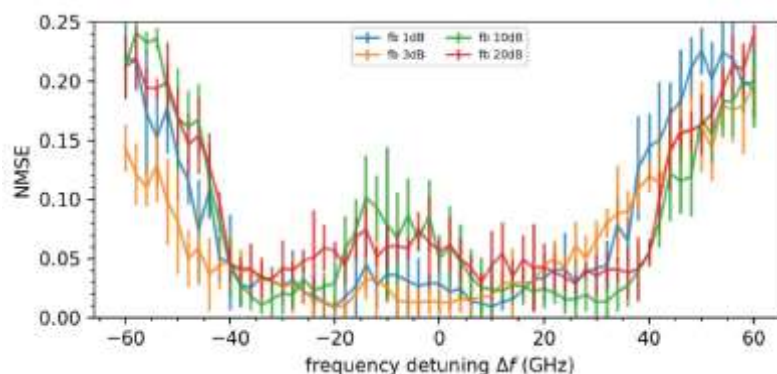

Figure 1. Experimental evaluation of the prediction error for an input time of 2.4 ns, virtual node separation of 12 ps and a feedback delay time of 24.5 ns while scanning the detuning for four different feedback attenuations in the feedback loop (color coded).

# 1

## PRESENTATION AND RESEARCH AREAS

# 2

PERSONNEL

# 2 PERSONNEL

## 2.1 PERMANENT SCIENTIFIC STAFF

|                           |   |
|---------------------------|---|
| APOSTOLOS ARGYRIS         | Associate Professor UIB                                 |
| PERE COLET                | CSIC Research Professor                                 |
| MIGUEL C. SORIANO         | CSIC Tenured Scientist                                  |
| ERNESTO ESTRADA           | CSIC Research Professor                                 |
| JUAN FERNANDEZ GRACIA     | CSIC Tenured Scientist                                  |
| ANTONIO FERNANDEZ PERALTA | Associate Professor UIB                                 |
| INGO FISCHER              | CSIC Research Professor                                 |
| TOBIAS GALLA              | CSIC Senior Researcher                                  |
| GIAN LUCA GIORGI          | Associate Professor UIB                                 |
| DAMIA GOMILA              | CSIC Tenured Scientist                                  |
| EMILIO HERNANDEZ GARCIA   | CSIC Research Professor, IFISC Director                 |
| LUCAS LACASA              | CSIC Senior Researcher                                  |
| CRISTOBAL LOPEZ           | University Full Professor UIB                           |
| ROSA LOPEZ                | University Full Professor UIB                           |
| VICTOR M. EGUÍLUZ         | CSIC Senior Researcher                                  |
| MANUEL MATÍAS             | CSIC Senior Researcher                                  |
| CLAUDIO MIRASSO           | University Full Professor UIB, IFISC Deputy Director    |
| MAXI SAN MIGUEL           | University Full Professor UIB, Emeritus                 |
| SILVIA ORTIN              | Associate Professor UIB (since December)                |
| JOSE J. RAMASCO           | CSIC Research Professor                                 |
| DAVID SANCHEZ             | University Full Professor UIB                           |
| LLORENÇ SERRA             | University Full Professor UIB, IFISC Academic Secretary |
| TOMAS SINTES              | University Full Professor UIB                           |
| RAUL TORAL                | University Full Professor UIB, HR Deputy Director       |
| ROBERTA ZAMBRINI          | CSIC Senior Researcher                                  |
| MASSIMILIANO ZANIN        | CSIC Tenured Scientist                                  |

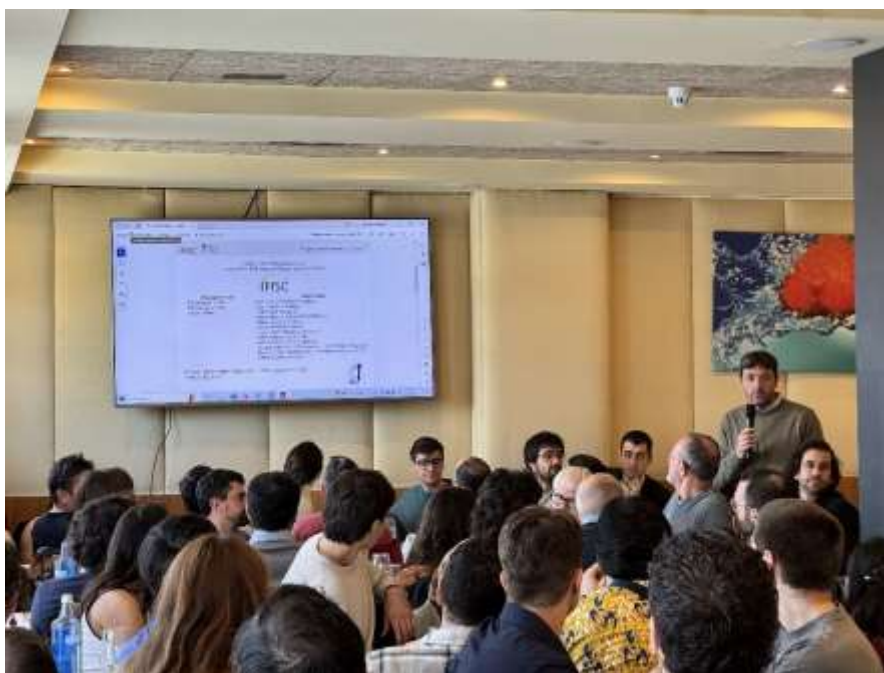

## Contribution of the permanent staff to the IFISC research areas:

Every senior researcher participates in the transversal area on Concepts and Tools. In addition, typically a senior researcher participates in one or two other focused lines. This collaborative organization provides coherence and integration as well as interaction and bridges. It is an alternative to static schemes with disjoint groups of researchers devoted exclusively to one line of research. The following table summarizes the participation of the senior researchers in the different areas during 2025.

|                         | <br>Concepts and Tools | <br>Photonics and Quantum Systems | <br>Life and Environment | <br>Social and socio-technical systems |
|-------------------------|---|--|---|---|
| Apostolos Argyris       | Yes   | Yes  | No  | No  |
| Pere Colet              | Yes   | No   | No  | Yes   |
| Miguel C. Soriano       | Yes   | Yes  | No  | No  |
| Ernesto Estrada         | Yes   | No   | Yes   | Yes   |
| Ingo Fischer            | Yes   | Yes  | No  | No  |
| Juan Fernández-Graña    | Yes   | No   | Yes   | Yes   |
| Toni Fernández          | Yes   | No   | No  | Yes   |
| Tobias Galla            | Yes   | No   | Yes   | No  |
| Gian Luca Giorgi        | Yes   | Yes  | No  | No  |
| Damià Gomila            | Yes   | No   | Yes   | Yes   |
| Emilio Hernández-García | Yes   | No   | No  | Yes   |
| Lucas Lacasa            | Yes   | No   | Yes   | Yes   |
| Cristóbal López         | Yes   | No   | Yes   | No  |
| Rosa López              | Yes   | Yes  | No  | No  |
| Manuel Matías           | Yes   | No   | Yes   | No  |
| Claudio Mirasso         | Yes   | No   | Yes   | No  |
| Víctor M. Eguiluz       | Yes   | No   | Yes   | Yes   |
| Silvia Ortín            | Yes   | Yes  | No  | No  |
| José Ramasco            | Yes   | No   | Yes   | Yes   |
| David Sánchez           | Yes   | Yes  | No  | No  |
| Maxi San Miguel         | Yes   | No   | No  | Yes   |
| Llorenç Serra           | Yes   | Yes  | No  | No  |
| Tomás Sintès            | Yes   | No   | Yes   | No  |
| Raúl Toral              | Yes   | No   | No  | Yes   |
| Roberta Zambrini        | Yes   | Yes  | No  | No  |
| Massimiliano Zanin      | Yes   | No   | Yes   | Yes   |

## 2.2 TENURE TRACK AND SENIOR RESEARCH FELLOWS

---

|                     |                              |
|---------------------|------------------------------|
| GONZALO MANZANO     | Ramón y Cajal                |
| ENRICO SER GIACOMI  | Beatriz Galindo              |
| MICHAEL MOSKALETS   | CSIC – Ukraine collaboration |
| LEONARDO LYRA GOLLO | Ramón y Cajal                |
| ALBERT CABOT        | Beatriz Galindo              |

## 2.3 SCIENTIFIC ASSOCIATES

---

HORACIO WIO  
 STEFANO LONGHI  
 JUAN CARLOS GONZALEZ-AVELLA  
 KONSTANTIN KLEMM  
 SANDRO MELONI  
 EDUARDO MORALEJO – since April

## 2.4 POSTDOCTORAL RESEARCH ASSOCIATES

---

|                          |                                      |
|--------------------------|--------------------------------------|
| KISHOR ACHARYA           | Project ARCTIC                       |
| ANDRES A. AGUADO         | Project UpMemo                       |
| LLUIS AROLA              | Maria de Maeztu                      |
| FEDERICO BELLISARDI      | Project DATAROAD                     |
| SREETAMA DAS             | Maria de Maeztu                      |
| JUAN IGNACIO DE GREGORIO | Project APASOS                       |
| RAUL DE PALMA            | Project TITAN                        |
| GABOR DROTOS             | Vicenç Mut CAIB                      |
| ELIANA FIORELLI          | Marie Curie fellow Project CoQHoNet  |
| GIAMPAOLO FOLENA         | Maria de Maeztu                      |
| CATHARINA E. GRAAFLAND   | Maria de Maeztu                      |
| ALEX GIMENEZ             | FUEIB Project GRAPHIB                |
| RUBEN HERZOG             | Contract associated to Ramon y Cajal |
| NATHAN KEENAN            | Project QNET                         |
| CLARA LAGO               | CAIB                                 |
| EVA M. LLABRES           | Marie Curie fellowship               |
| PABLO MORENO SPIEGELBERG | Project CYCLE                        |
| JAUME OJER               | Maria de Maeztu                      |
| FELIPE E. OLIVARES       | Project CATSUIT                      |
| JAVIER OSCA              | Assistant Professor UIB              |

|                       |                             |
|-----------------------|-----------------------------|
| PAULO J. PAULINO      | Project Quantum Spain       |
| MORITZ P. D. PFLUEGER | INFOLANET Project           |
| RICARD RAVELL         | Margalida Comas Programme   |
| DANIEL RUIZ REYNÉS    | MOMENTUM Programme          |
| SUNGGUEN RYU          | Assistant Professor UIB     |
| NATHAN SILVANO        | Maria de Maeztu             |
| LUISA TOLEDO          | Project COQUADIS            |
| MIHIR S. UMARANI      | LOCAL CORAL SPECIES Project |
| VASILEOS VARGIAMIDIS  | Project MAGMA               |
| FEDERICO VAZQUEZ      | Project APASOS              |
| FRANCESCO VENTRELLA   | Project LAMARCA             |
| KAICHAO WU            | Juan de la Cierva           |

## 2.5 PHD STUDENTS

---

|                           |   |
|---------------------------|---|
| JOSE ANTONIO ALMANZA      | FPI Baearic Government                        |
| ALEJANDRO ALMODOVAR       | UIB contract                                  |
| MIGUEL ALVAREZ            | FPI Maria de Maeztu                           |
| SANDOR BATTAGLINI         | Project Postdigital+                          |
| JOSU BLANCO               | FPI Balear Government                         |
| GORKA BUENVARON           | FPI Maria de Maeztu                           |
| CARLSON M. BÜTH           | Project ARCTIC                                |
| ANNALISA CALIGIURI        | FPI Maria de Maeztu                           |
| CANIGÓ CALLAU I BOIX      | Project APASOS                                |
| STEFANO CAMPAGNOLA        | Contract associated to Beatriz Galindo fellow |
| ALBERT CAÑELLAS           | Technician contract. Project QUPROCS          |
| DIMITRIOS CHALKIADAKIS    | FPI Alicante University cotutelle             |
| ANTONIO COLL DE SAN SIMON | Maria de Maeztu                               |
| MATEU COLL COMAS          | Project Quantum Spain                         |
| PARIDE CRISAFULLI         | Maria de Maeztu                               |
| JOAN CUCURULL             | FPI Balear Government                         |
| MAR CUEVAS                | FPI MISLAND Project                           |
| FERNANDO DIAZ             | FPI Maria de Maeztu                           |
| PAU ESTEVE                | FPI Balear Government                         |
| JAVIER GALVAN             | Contract associated to Ramon y Cajal          |
| ASIER GARAY               | UIB - IKERLAN cotutelle                       |
| JORGE GARCIA BENI         | FPI Balearic Government                       |
| JUAN A. GARCIA CASTILLO   | FPI Maria de Maeztu                           |
| GEMMA INFANTES            | Project NEHIL                                 |

|                          |   |
|--------------------------|---|
| LUIS IRISARRI            | Empleo Junenil del Fondo Social Europeo |
| PEDRO JIMENEZ            | FPI Maria de Maeztu                     |
| ADRIA LABAY              | Maria de Maeztu                         |
| JAUME LLABRES            | UIB contract                            |
| GUILLEM LLODRA           | Project CoQuSy                          |
| RAUL LOPEZ               | FPU Contract                            |
| ALBA MAYOR               | Empleo Joven CSIC                       |
| JORGE MAMPEL             | European Ocean Citizen Project          |
| JORGE MEDINA             | Project MISLAND                         |
| MANUEL MIRANDA           | FPI Project Operadores                  |
| MOHAMMADREZA MOKHTARI    | Project Postdigital+                    |
| PORIKSHIT MONDAL         | Project SNANDOG                         |
| DANIEL MONTESINOS        | La Caixa – UIB contract                 |
| JESUS A. MORENO          | Maria de Maeztu                         |
| PABLO MORENO SPIEGELBERG | Project CYCLE                           |
| ORIOI MORGUÍ             | COQUSY Project                          |
| ADHILA NAZARUDEEN        | Project Postdigital+                    |
| CARLOTTA NUNZI           | FPI Maria de Maeztu                     |
| SARA OLIVER              | FPU fellow                              |
| DAVID ORTIZ              | FPI APASOS Project                      |
| IRIS M.A. PAPARELLE      | UIB - Sorbonne Univ., Paris cotutelle   |
| JUANA M. PAGAN           | UIB - REGENERA cotutelle                |
| MUHAMMAD RIAZ            | Project Postdigital+                    |
| JUAN C. RODRIGUEZ        | FUEIB contract                          |
| PABLO ROSILLO-RODES      | FPI Maria de Maeztu                     |
| ANTONIO SANNIA           | INPHINIT fellow Fundacio La Caixa       |
| IVAN SEVOSTIANOV         | Maria de Maeztu                         |
| LUCAS TRIGAL             | JAE predoctoral contract                |
| SERGIO VIDAL             | Maria de Maeztu                         |
| XIN WEN                  | Chinese Government fellowship           |

## 2.6 TECHNICAL AND ADMINISTRATIVE SUPPORT

---

|                           |  |
|---------------------------|--|
| MIGUEL ARTIGUES           | Computing Lab Data Engineer CAIB                 |
| RAQUEL BOTET              | AGE servent – since November                     |
| DANIEL COBO               | Contract Formación en alternancia                |
| MAGDALENA ESCALES         | Project DATAROAD                                 |
| ISABEL F. GALVEZ          | FUEIB  |
| ADRIAN GARCIA CANDEL      | Communication and Dissemination                  |
| DAVID JIMENEZ             | Maria de Maeztu                                  |
| NEUS LACOMBA              | UIB Proximity Technician                         |
| CARMEN M. MARTÍNEZ        | Deputy Manager                                   |
| SIMONA OBREJA             | Project Manager                                  |
| MARTA OZONAS              | IFISC Administration                             |
| REBECA PEREZ              | Administration Technician                        |
| ALBERTO J. SANCHEZ        | Accounting Administration                        |
| AKSHAY TIWARI             | Technician Project RE-TE. ERC - Proof of Concept |
| RUBEN TOLOSA              | Computing Lab Technician                         |
| M. ANTONIA TUGORES        | Data Engineer                                    |
| FATIMA Z. VELASQUEZ ROJAS | Management Support Project TRAOC                 |



## 2.7 VISITORS

**LONG-TERM VISITORS**  
(more than one month)

|                         |  |
|-------------------------|--|
| ENRIQUE CANO            | Univ. San Jorge, Zaragoza (March – April)  |
| ANA RUIZ VARONA         | Univ. San Jorge, Zaragoza (March – April)  |
| ANA M. MARTINS SEQUEIRA | Univ. of Western, Australia (June-July)    |
| TAHA YASSERI            | Trinity College Dublin, Germany (Oct- Nov) |
| FILIPPO DALLA           | Univ. of Bologne, Italy (Oct- Marc)        |

**SHORT-TERM VISITORS**  
(Less than one month)

|                             |  |
|-----------------------------|--|
| CELIA ANTENEODO             | PUC-Rio, Rio de Janeiro, Brazil (February)     |
| KUN WOO KIM                 | Chung-Ang Univ., South Korea (February)        |
| ANTONIS TSAKONAS            | Democritus Univ. of Tharce, Greece (June)      |
| MICHAL HORODECKI            | Univ. of Gdansk, Poland (February)             |
| CHRISTOPH HAUERT<br>(April) | Univ. of British Columbia, Vancouver, USA      |
| ROBERT LEGENSTEIN           | Graz Univ. of Technology, Austria (April)      |
| FRANCESCO BERTOLOTTI        | LIUC, Univ. Cattaneo, Italy (May)              |
| LUCIANO ABADÍAS             | Univ. of Zaragoza, Spain (May)                 |
| ANA SEQUEIRA                | Univ. of Western, Australia (July)             |
| ALBERTO AMADUCCI            | Fundazione Bruno Kessler, Trento, Italy (July) |
| VRISHALI SONAR              | Adam Mickiewicz Univ., Poland (July)           |
| RONNY THOMALE               | Univ. Wüzburg, Germany (October)               |
| MOHAB ABDALLA               | Univ. Centrale Supélec, France (October)       |
| GERALD KOBI                 | Univ. Centrale Supélec, France (October)       |

# 2 PERSONNEL



## 2.8 MASTER AND COLLABORATION STUDENTS

In addition to the IFISC personnel, master and collaboration students have been also involved in IFISC research:

### 2024-2025 IFISC Master

DAVID CARPIO  
MATEU COLL  
JOAN CUCURULL  
MARCO FISCAL  
PABLO GALLARDO  
ADAM C. MACKOWIAK  
DANIEL MARTINEZ  
SAKANDER ZIRAI  
SERGIO ZUCCHI

### 2025-2026 IFISC Master

ALEX BRUGUERA  
ALEX CAPA  
DAVID M. CARPIO  
ALEIX CASALS  
MIGUEL CERDÁN  
ANA COLOMO  
JAVIER DE CABO  
ANDREU FIOL  
MANUEL FORONDA  
ZENAIDA GARCÍA  
DIEGO I. GARCÍA  
DIEGO GARRIDO  
SYLVAIN HAMERS  
IKER LOMAS  
ADAM C. MACKOWIAK  
ALBERTO MARTINEZ  
ANGELO MONTELEONE  
RAQUEL MUNK  
ALVARO PALLAS  
JORGE RODRIGUEZ TOLEDO  
CHRISTIAN SOLIS  
YE-EUN SONG

### Collaboration students

|                             |   |
|-----------------------------|---|
| SANDOR BATTAGLINI           | ERASMUS Univ. of Amsterdam, Netherlands (Jan. - July) |
| ALESSANDRO ROMANCINO        | Univ. of Palermo, Italy (Feb.-July)                   |
| MARCO VETRANO               | Univ. of Palermo, Italy (Feb.-July)                   |
| DARIO ZARCONE               | Univ. of Palermo, Italy (March – July)                |
| MARIUS MAVRIDIS             | ENS Paris, Saclay, France (March – July)              |
| ALIA DAUPHIN                | ENS Paris, Saclay, France (March –June)               |
| PAUL DE VILLIERS DE LA NOUE | ENS Paris, Saclay, France (March –June)               |
| MACARENA AMIGO              | Univ. Buenos Aires, Argentina (April –June)           |
| NURIA GARCIA AGUADO         | Univ. Complutense Madrid, Spain (April –June)         |
| SAGE WIDDER                 | Wellesley College, MA, USA (June –July)               |
| SARA FINOCCHIARO            | Univ. of Insubria, Como, Italy (June- Dec.)           |
| LUCA NIGRO                  | Università degli studi di Milano, Italy (Sept- March) |
| NIKITAS KYRIAKIDIS          | ERASMUS WUR, Netherlands (Sept-March)                 |
| PIETRO DE CCHECCHI          | Univ. of Padova, Italy (November)                     |

## 2.9 HUMAN RESOURCES OVERVIEW

### HUMAN RESOURCES IFISC 2025

|                               | Total      | Male       | Female    |
|-------------------------------|------------|------------|-----------|
| Permanent staff               | 26         | 23         | 3         |
| Tenure track & senior fellows | 11         | 11         | 0         |
| Postdoctoral fellows          | 32         | 26         | 6         |
| PhD students                  | 54         | 44         | 10        |
| Long-term visitors            | 5          | 3          | 2         |
| Support personnel             | 17         | 7          | 10        |
| <b>Total</b>                  | <b>145</b> | <b>114</b> | <b>31</b> |

### PERSONNEL IFISC 2020-2025

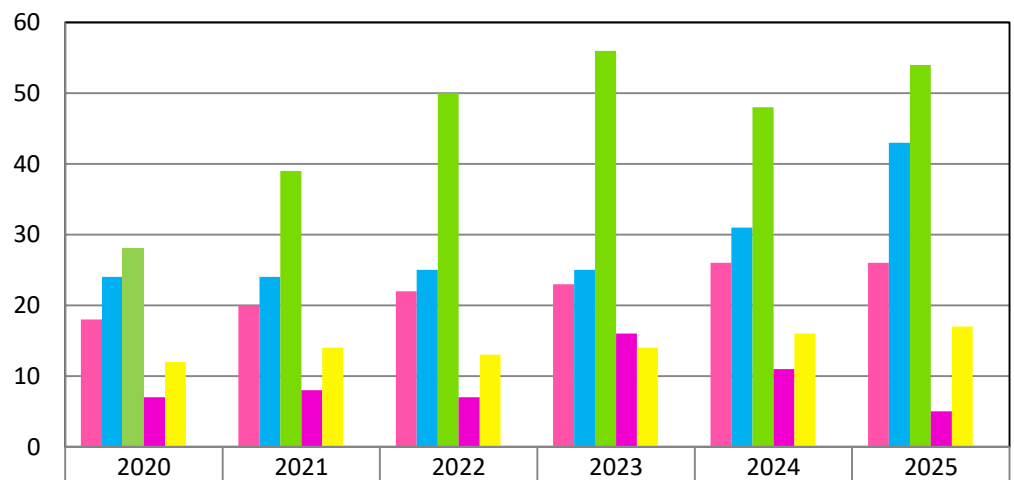

|                                |           |            |            |            |            |            |
|--------------------------------|-----------|------------|------------|------------|------------|------------|
| PERMANENT STAFF                | 18        | 20         | 22         | 23         | 26         | 26         |
| POSTDOCS, SENIORS & ASSOCIATED | 24        | 24         | 25         | 25         | 31         | 43         |
| PHD STUDENTS                   | 28        | 39         | 50         | 56         | 48         | 54         |
| LONG TERM VISITORS             | 7         | 8          | 7          | 16         | 11         | 5          |
| SUPPORT PERSONNEL              | 12        | 14         | 13         | 14         | 16         | 17         |
| <b>TOTAL</b>                   | <b>89</b> | <b>105</b> | <b>117</b> | <b>134</b> | <b>132</b> | <b>145</b> |

**VISITING SCIENTISTS AT IFISC 2025**

---

|  |                   | Short visits | Long visits | Total visits |
|--|-------------------|--------------|-------------|--------------|
|  | SPAIN             | 1            | 2           | 3            |
|  | EUROPE            | 9            | 2           | 11           |
|  | REST OF THE WORLD | 4            | 1           | 5            |
|  | TOTAL             | 14           | 5           | 19           |



# 2 PERSONNEL

# 3

## RESEARCH PROJECTS AND FUNDING

# 3

## RESEARCH PROJECTS AND FUNDING

**DURING 2025 IFISC HAS RECEIVED FUNDING VIA THE ACTIVE RESEARCH PROJECTS LISTED IN THE FOLLOWING PAGES. IN BRIEF:**

- European Commission Framework Program projects: **10**
- Spanish National Plan: **17**
- Collaboration Networks: **4**

Grand total budget of active projects in 2025: **8.909.359 €**  
 Average yearly project funding in 2019-25: **2.022.594 €**  
 Average EC funding in 2019-25: **39,71 % of total**

**BUDGET FIGURES FOR THE PERIOD 2019-2025 ARE SUMMARIZED IN THE FOLLOWING TABLE**  
 (With budget of a project assigned to the year it is granted. The *Annualized total* is the sum of one-third of the budget granted in that year and in the two previous years):

**BUDGET IFISC’S RESEARCH PROJECTS 2019-2025 (IN €)**

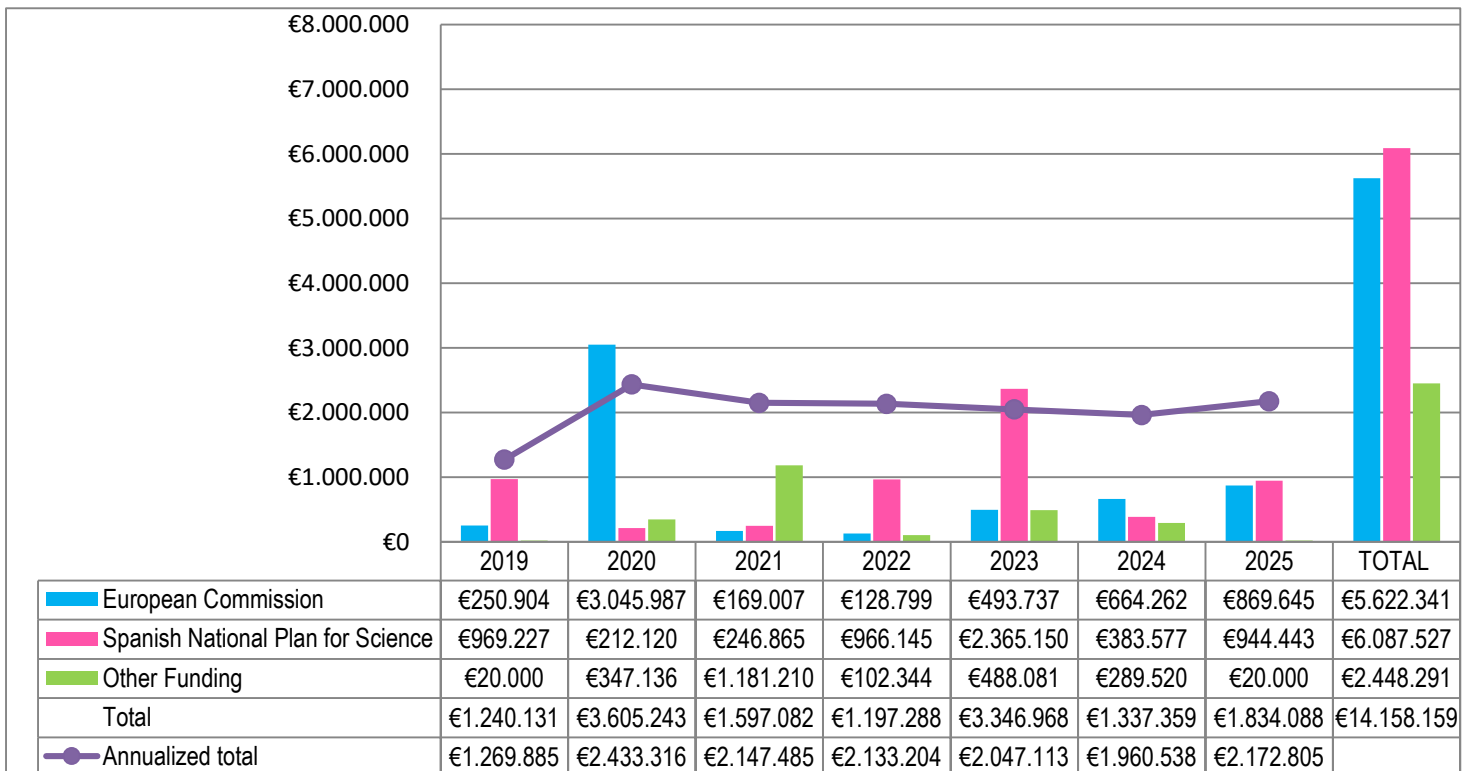

## 3.1 RESEARCH FUNDED BY THE EUROPEAN COMMISSION

## Hybrid

**New hybrid methods to study and forecast flight delay propagation.** SESAR Subproject. [101114648] CSIC, Principal Investigators: Jose Ramasco and Massimiliano Zanin (2024-2027) Budget: 60.000€

## RE-TE

**Regional Economy / Travel Expectations.** [101112847] ERC Proof of Concept. Principal Investigator: Massimiliano Zanin (2023-2025) Budget: 150.000€

## CoQHoNet

**Connecting Quantum Hopfield Networks.** [IP-101105267] Marie Curie Intra-European Fellowships for career development. Principal Investigator: Roberta Zambrini (2023-2025) Fellow: Eliana Fiorelli. CSIC Budget: 165.312,96€

## Ocean Citizen

**Marine forest coastal restoration: an underwater gardening socio-ecological plan.** [HORIZON-MISS-2021-OCEAN-02: 101093910] Innovation Action. Principal Investigator: Damià Gomila (2023-2026) CSIC Budget: 178.424,70€



## POSTDIGITALPlus

**European Training Network on Post-Digital Computing+.** [101169118] Principal Investigators: Claudio Mirasso and Miguel C. Soriano (2025-2029) Budget: 1.007.884,80€

## ARCTIC

**Air Transport as Information and Computation.** European Research Council Starting Grant [851255] IFISC Principal Investigator: Massimiliano Zanin. (2020-2025) Budget: 869.644,80 €

**MAGMA**

**Magnetic topological insulators for robust majorana bound states.** International collaboration Project AEI-PCI-ERA. (2022-2025) Principal Investigator: Llorenç Serra. UIB Budget: 128.799,96 €

**CoQuaDis**

**Collective quantum phenomena in dissipative systems – towards time-crystal applications in sensing and metrology.** [PCI2024-153446] AEI-PCI-ERA International Collaboration Project. Principal Investigator: Roberta Zambrini (2024-2027) CSIC Budget: 187.500€

**QNet**

**Transport, metastability, and neuromorphic applications in quantum networks.** [PCI2024-153410] AEI-PCI-ERA International Collaboration Project. Principal Investigators: Roberta Zambrini and Gian Luca Giorgi (2024-2027) UIB Budget: 187.500€

**SIESTA**

**Secure Interactive Environments for SensiTive data Analytics.** [101131957] Research and Innovation Action (RIA) Principal Investigators: Pere Colet and Jose Ramasco (2024-2026) Total Budget: 4M. CSIC Budget: 229.262€

**3.2 RESEARCH PROJECTS OF THE SPANISH NATIONAL PLAN FOR SCIENCE****MdM – IFISC -2**

**Accreditation of IFISC as “Maria de Maeztu, Unit of Excellence”.** [CEX2021-001164-M] Principal Investigator: Claudio Mirasso. (2023-2026) Budget: 2.000.000€

**INFOLANET**

**Information processing with coupled laser networks.** [PID2022-139409NB-I00] Principal Investigators: Apostolos Argyris and Miguel C. Soriano (2023-2026) Budget: 127.500€

**CoQuSy**

**Complex Quantum Systems: machine learning, thermodynamics and emergent phenomena.** [PID2022-140506NB-C21 y C22] Principal Investigators: Gian Luca Giorgi, Roberta Zambrini and Gonzalo Manzano (2023-2026) CSIC Budget: 148.750€. UIB Budget: 112.500€.

**SNANDOG**

**Spatiotemporal Nonlocal and Non-conservative Diffusion on Graphs.** [PID2023-149473NB-I00] CSIC. Principal Investigator: Ernesto Estrada (2024-2026) CSIC Budget: 58.625€

**SuMQuTT**

**Surfing Multiterminal Quantum Thermodynamics and Topology.**  
[PID2023-151975NB-I00] UIB. Principal Investigators: Rosa López and Lorenc Serra (2024-2028) UIB Budget: 125.000€

**CATSUIT**

**Climbing at the Source of Irreversibility.** [CNS2023-144775] Principal Investigator: Massimiliano Zanin (2024-2026) CSIC Budget: 199.952€

**APASOS**

**A Physics approach to sociotechnical systems: from theory to data analysis** [PID2021-122256NB-C21/C22] (2022-2025) Principal Investigators: Tobias Galla, Sandro Meloni, Maxi San Miguel and Raul Toral. Budget: UIB: 193.600 € and CSIC: 181.500 €

**CYCLE**

**Complex DYNamics of Coastal Ecosystems: Resilience to Climate Change. Modelling and Simulations.** [PID2021-123723OB-C22] (2022-2025) Principal Investigators: Tomas Sintes and Damia Gomila. Budget: 124.630 €

**LAMARCA**

**Lagrangian transport of marine litter and microplastics in coastal waters: structures of transport and connectivity patterns** [PID2021-123352OB-C32] Principal Investigators: Emilio Hernández-García, Cristóbal López (2022-2026) CSIC Budget: 102.850 €

**UpMEMO**

**Updating the brain's memory base: computational perspective** [PID2021-128158NB-C22] Principal Investigator: Claudio Mirasso (2022-2025) Budget: 340.365 €

**ANCHOR**

**Advancing fragility Connectomics for Health studies, neurodegenerative disorders.** [PID2024-162343OB-I00] Principal Investigator: Leonardo Lyra Gollo. (2025-2029) Budget: 125.000€

**CHANGE-ME**

**Complex Ecological Systems and their Resilience to Global Change: Marine Coastal Ecosystems and Plant Epidemics.** [PID2024-156062OB-I00] Principal Investigators: Damià Gomila and Manuel Matias (2025-2028) Budget: 125.000€

**CoSASTI**

**Complex Systems Approach to Social and Technological Interactions.** [PID2024-157493NB-C21/C22] Principal Investigators: Tobias Galla, Jose Ramasco, David Sanchez and Raúl Toral (2025-2028) Budget: 227.500€

**CSxAI**

**Complexity science for understanding AI: from the dynamics of complex networks to collective effects of interacting neural networks.** [PID2024-157526NB-I0] Principal Investigators: Lucas Lacasa and Victor M. Eguiluz (2025-2028) Budget: 112.500€

**TITAN**

**Temporal Interference and Twin-Augmented Neuromodulation for enhancing memory formation.** [PID2024-162400OB-C21] Principal Investigators: Claudio Mirasso and Silvia Ortín. (2025-2028) Budget: 125.000€

**WAGNER**

**Warping of graph and network representations.** [PID2024-158605NA-I00] Principal Investigator: Massimiliano Zanin (2025-2028) Budget: 31.875€

**QUANTCOM**

**Exploring the Intersection of Quantum Phenomena and Next-Generation Computing.** [CNS2024-154720] Principal Investigator: Gian Luca Giorgi (2025-2027) Budget: 197.568€

**3.3 OTHER PUBLIC AND PRIVATE FUNDING****AISAI**

**Aerial identification of seagrass meadows at risk using artificial intelligence.** Project of the Càtedra de la Mar Iberostar Foundation Principal Investigator: Daniel Ruiz Reynolds (2024-2025) UIB Budget: 12.000€

**UCRAN20029**

**Floquet quantum information processing devices.** Acción Complementaria. Principal Investigator: David Sánchez. Fellow: Michael Moskalets (2022-2026) CSIC Budget: 217.590,46 €

**Quantum Spain**

Principal Investigator: Roberta Zambrini (2023-2025) Agreement. Budget: 273.404€

**EUR2J**

**De l'Euro al Joule.** Principal Investigator: Raul Toral. La Caixa Foundation (2023-2025) UIB Budget: 107.902€

**QTD-InFlexity**

**Quantum thermodynamics: information, fluctuations and complexity.** [20235AT009] PIE - Proyecto Intramural Especial associated to Ramon y Cajal. Principal Investigator: Gonzalo Manzano (2023-2026) CSIC Budget: 50.000€

## BOND

**Brain Network Organization and Dynamics.** [20245MAX011]  
 Proyecto Intramural Especial associated to Ramon y Cajal. Principal Investigator: Leonardo Lyra Gollo (2024-2027) CSIC Budget: 183.333,33€

## KCRI-ENCOREDAT

**Enhancing coral reef restoration success through data-driven projections of future reef formation.** Excellence Network. UIB. Principal Investigators: Manuel Matías and Damià Gomila (2024-2026) UIB Budget: 11.200\$

## ChaLueCo

**Chateo, Luego Coopero: IA y humanos en redes complejas.**  
 [PIA24] Project with COTEC Foundation. Principal Investigator: Jose J. Ramasco (2025-2026) Budget: 20.000€

## 3.4 RESEARCH PROJECTS AND COLLABORATION NETWORKS WITH PARTICIPATION OF IFISC MEMBERS

## MOBILITY2030

**Sustainable and healthy urban mobility.** CSIC Interdisciplinary Thematic Platform (PTI). Principal Investigator at IFISC: J.J. Ramasco

## Global Health

**Global Health.** CSIC Interdisciplinary Thematic Platform (PTI+). Principal Investigator at IFISC: J.J. Ramasco

## AIHUB

**HUB CSIC for fomenting the research and services on Artificial Intelligence.** CSIC Interdisciplinary Thematic Platform (PTI). Principal Investigator at IFISC: J.J. Ramasco

## QTEP

**Quantum Technologies Platform.** CSIC Interdisciplinary Thematic Platform (PTI+). Main Investigator at IFISC: Roberta Zambrini

### 3.5 RESEARCH CONTRACTS

## GRAPHIB

**Validació d'un model de graus-dia per predir l'aparició de les primeres nimfes de *Philaenus spumarius* a les Illes Balears.** Contrato de servicios FUEIB-CAIB. Principal Investigator: Manuel Matías (2024-2027) Budget: 603.465,72€

## 3.6 NON-DISCLOSURE AND COLLABORATION AGREEMENTS WITH NON-ACADEMIC INSTITUTIONS



DATA & ANALYTICS



# 4

IFISC  
SEMINARS

# 4

IFISC SEMINARS

Coordinator:  
**Tobias Galla**

A total of 113 seminars, including weekly regular seminars and talks, were given at IFISC in 2025. The full list of seminars can be found at the website: <http://ifisc.uib-csic.es/en/events/seminars/> as well as in the Appendix of this report.

Seminars are broadcasted live and recorded. They are globally available at <http://ifisc.uib-csic.es/en/events/seminars/>, and also on our youtube channel <https://www.youtube.com/user/IFISCseminars/>





### Criticality and Hierarchy of Brain Dynamics

**Fundament 1: Criticality**

■ Active  
○ Inactive

$\sigma > 1$

$\sigma = 1$

$\sigma < 1$

Subcritical

Critical

Supercritical

Kinouchi and Copelli (2006), Nature

Wu and Galla, 2025

1. Criticality is a state where the brain network operates near a phase transition, exhibiting a delicate balance between ordered and disordered activity patterns.

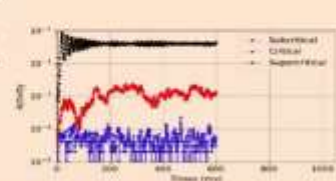
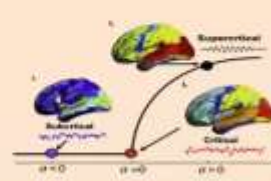

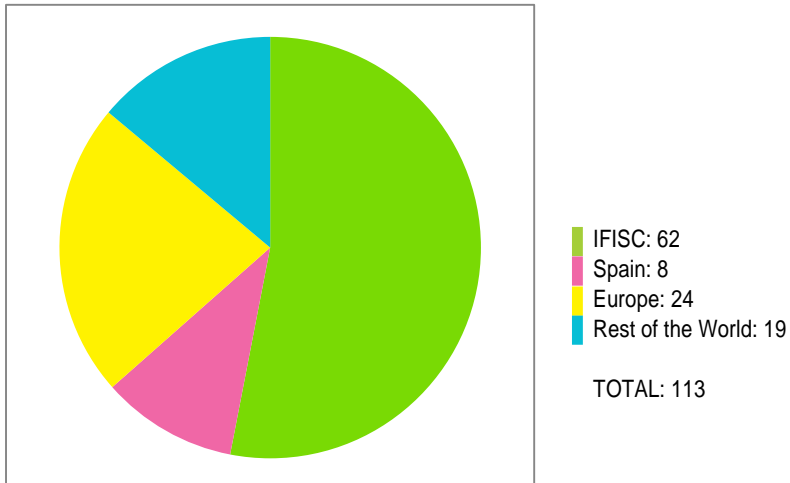

The following graphs show the distribution of seminars by geographical provenance of the speaker for 2025 and for the previous years:

### PROVENANCE OF SPEAKERS AT IFISC SEMINARS 2025

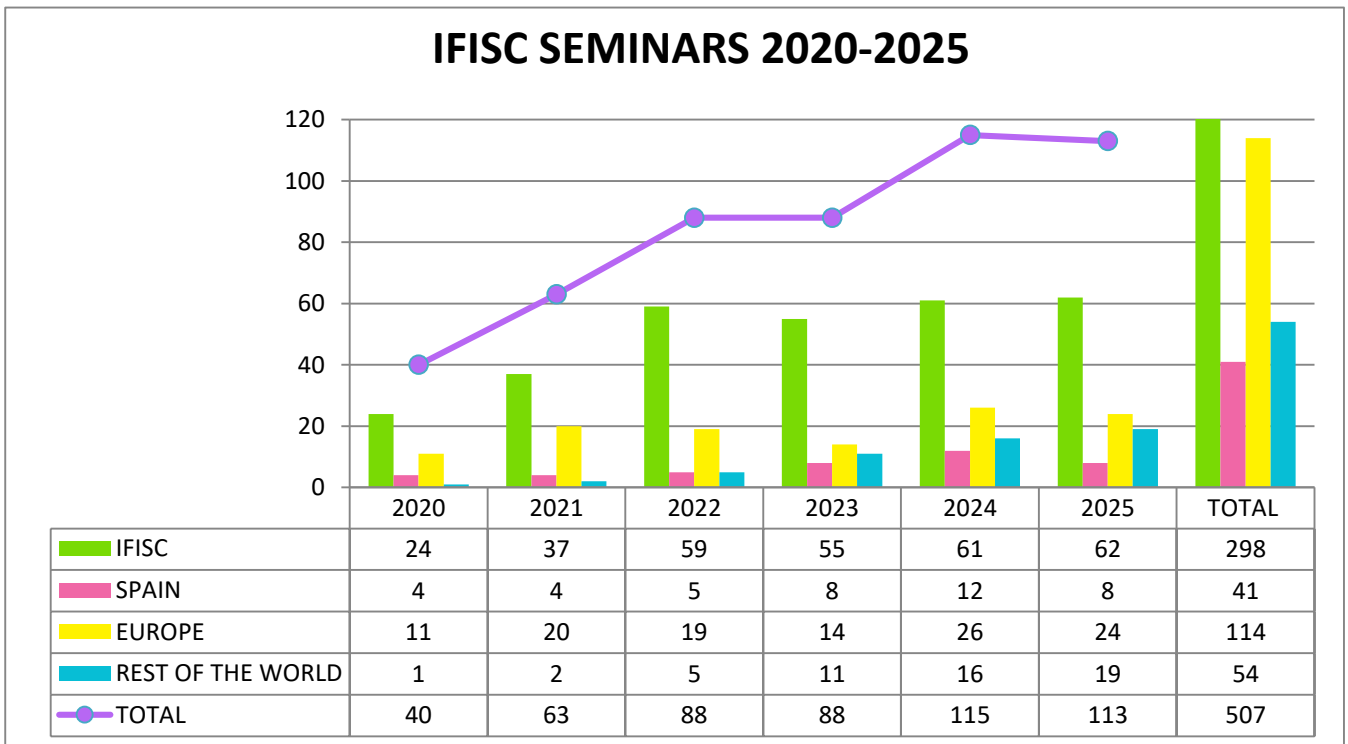

### IFISC SEMINARS 2020-2025



# 5

## PUBLICATIONS

# 5 PUBLICATIONS

### IFISC RESEARCH RESULTS HAVE BEEN REPORTED IN THE FOLLOWING PUBLICATIONS DURING 2025:

- Papers in indexed journals: **118**
- Other publications: **5**

The following tables place these numbers in the context of the publication activity during the past years, specifying the main journals in which IFISC papers are published. It is a strategic commitment of IFISC to target cross-disciplinary research areas lying outside the domain of traditional physics. The success in this objective is highlighted in the tables by indicating the number of publications in *non-physics journals*.

With respect to publications in high impact journals, in 2025 IFISC has published 1 in Science, 1 in PNAS, 5 in Physical Review Letters, 2 in Communications Physics, and 1 in Communications Biology.

- Non Physics Journals: **33**
- High Impact Journals: **9**

Full listing of publications and links to the full text are available here: <http://ifisc.uib-csic.es/en/publications/> and in the Appendix of this Report.

### IFISC PUBLICATIONS 2020-2025

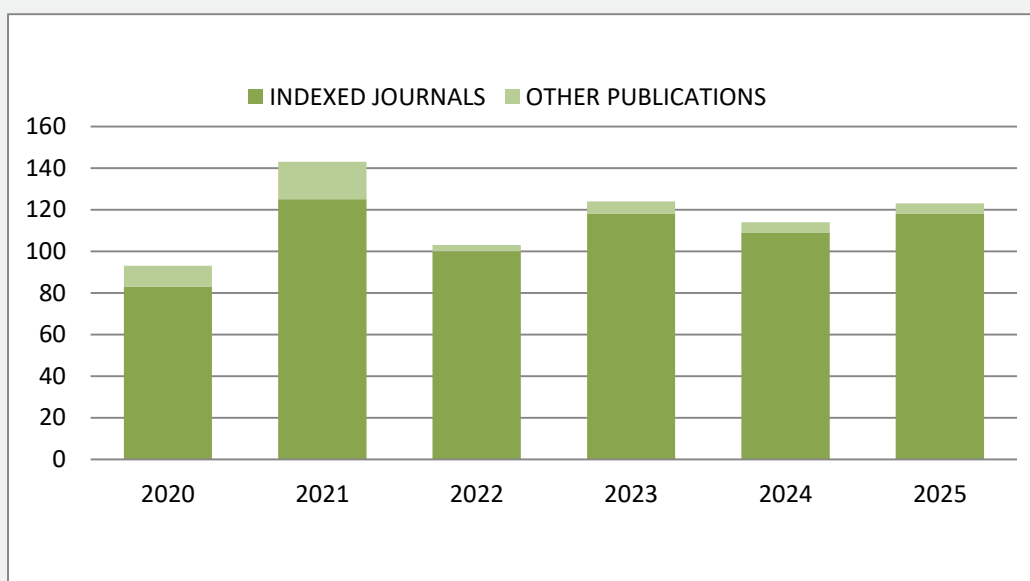

|                    | 2020 | 2021 | 2022 | 2023 | 2024 | 2025 | TOTAL |
|--------------------|------|------|------|------|------|------|-------|
| INDEXED JOURNALS   | 83   | 125  | 100  | 118  | 109  | 118  | 653   |
| OTHER PUBLICATIONS | 10   | 18   | 3    | 6    | 5    | 5    | 47    |
| <b>TOTAL</b>       | 93   | 143  | 103  | 124  | 114  | 123  | 700   |

## JOURNALS WITH THE LARGEST NUMBER OF PUBLICATIONS

| IFISC PUBLICATIONS                | 2020 | 2021 | 2022 | 2023 | 2024 | 2025 | TOTAL |
|-----------------------------------|------|------|------|------|------|------|-------|
| <b>Physics journals</b>           |      |      |      |      |      |      |       |
| Physical Review E                 | 3    | 9    | 10   | 14   | 6    | 10   | 52    |
| Chaos                             | 8    | 5    | 1    | 10   | 3    | 5    | 32    |
| Physical Review B                 | 5    | 7    | 4    | 7    | 3    | 5    | 31    |
| Optics Letters                    | 7    | 5    | 4    | 5    | 7    | 5    | 33    |
| Physical Review Letters           | 2    | 4    | 4    | 3    | 2    | 5    | 20    |
| New Journal of Physics            | 2    | 5    | 3    | 1    | 1    | 1    | 13    |
| Physical Review A                 | 2    | 2    | 3    | 0    | 2    | 2    | 11    |
| <b>Multidisciplinary journals</b> |      |      |      |      |      |      |       |
| Scientific Reports                | 5    | 8    | 8    | 7    | 3    | 5    | 36    |
| Nature Communications             | 2    | 4    | 5    | 2    | 7    | 0    | 20    |
| Plos One                          | 3    | 0    | 3    | 0    | 0    | 1    | 7     |
| <b>IEEE journals</b>              |      |      |      |      |      |      |       |
|                                   | 4    | 3    | 4    | 2    | 1    | 1    | 15    |
| <b>Other non-physics journals</b> | 11   | 40   | 20   | 24   | 23   | 32   | 150   |

The journals included in the “other non-physics journals” category are the following:

### **Biosciences:**

Communications Biology, PLoS Computational Biology, NPJ Systems Biology and Applications, Ecology Letters, Ecological Indicators, Current Biology, Biomedical Physics and Engineering Express.

### **Earth sciences:**

PLoS Clim, Nonlinear Processes in Geophysics, Movement Ecology, Marine Pollution Bulletin, Global Ecology and Biogeography, European Journal of Forest Research, Earth System Dynamics, Coral Reefs.

### **Sociotechnical and Social systems:**

Transportation Research Interdisciplinary Perspectives, Journal of Modern Power Systems and Clean Energy, Journal of Air Transport Management, Journal on Computing and Cultural Heritage, Energies, Aerospace, IEEE Transactions on computational social systems.

### **Data science, Neural Computation and Machine learning:**

Communications in Nonlinear Science and Numerical Simulation, Special Matrices, SIAM Journal on Matrix Analysis and Applications, Scientific Data, Neuroscience, Neuropsychopharmacology, Mathematics, Information Sciences, Expert Systems with applications, EPJ Data Science, Engineering Failure Analysis.

# 6

## CONFERENCES AND WORKSHOPS

# 6

## CONFERENCES AND WORKSHOPS

6.1 PRESENTATIONS AT SCIENTIFIC CONFERENCES 2025

- Invited talks: **46**
- Oral presentations: **38**
- Posters: **73**
- Total in 2025: **157**

Full listing in the Appendix of this Report.

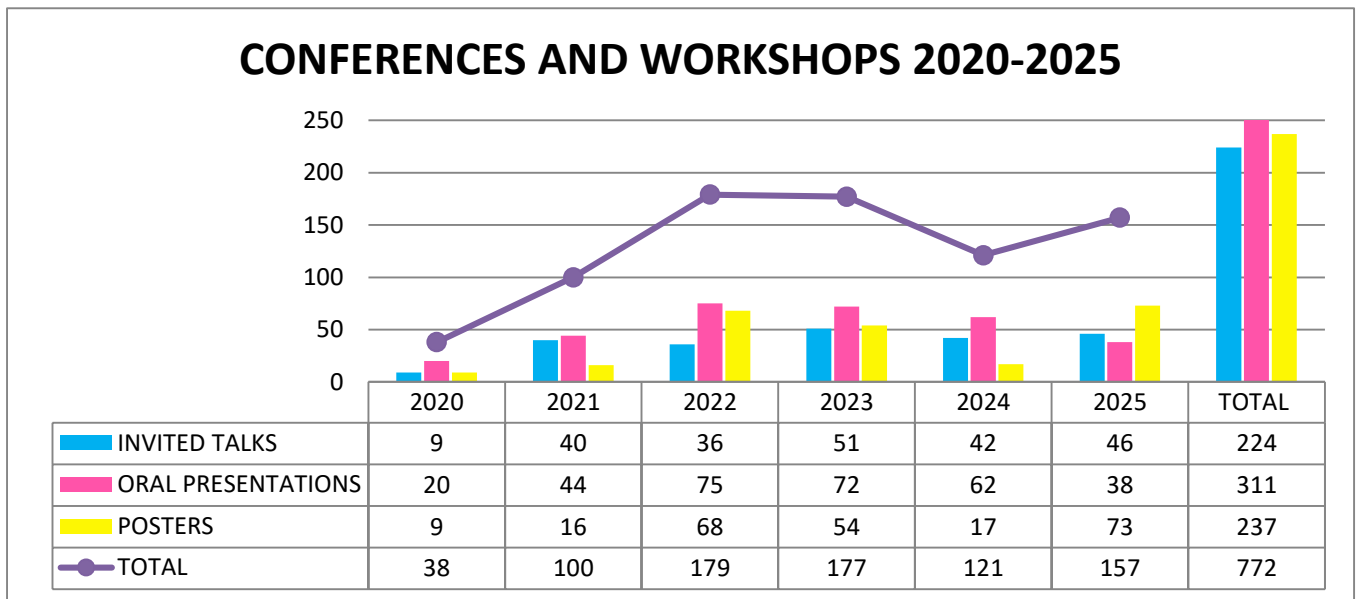

## 6.2 ORGANIZATION OF CONFERENCES AND WORKSHOPS

---

**4th Conference on Nonlinear Processes in Oceanic and Atmospheric Flows. Barcelona, Spain.**  
Lopez, C.; Hernandez-Garcia, E.

**Satellite organization at CCS2025. Siena, Italy.**  
Meloni, Sandro

**Satellite on mobility and urban systems of the CCS2025, Siena, Italy.**  
Ramasco, JJ

**CompLa2025 (Complexity in Language 2025), CCS25 satellite, Siena, Italy.**  
Sánchez, D.

**Winter Workshop on Complex Systems 2025, Lombardy, Italy.**  
Rosillo-Rodes, Pablo

**Satellite event MC20 - Neuromorphic computing with complex systems, in the CMD31 conference, Braga, Portugal**  
Zambrini, Roberta

**FISES Joven.**  
Rosillo-Rodes, P.

**II Congreso Español sobre Investigación en Movilidad, Zaragoza, Spain.**  
Ramasco, JJ

**Photonics Meets Neuroscience @65. Palma de Mallorca, Spain.**  
Ortín, Silvia; Lyra Gollo, Leonardo; C. Soriano, Miguel; Argyris, Apostolos

**Women for Quantum III, Mallorca, Spain**  
Zambrini, Roberta

**Mallorca topological quantum matter, Palma de Mallorca, Spain.**  
Serra, Llorenç; Osca, Javier

**XII GEFENOL Summer School on Statistical Physics of Complex Systems. Barcelona, Spain.**  
Colet, Pere

**Complex Networks 2025. Binghamton, NY, USA.**  
Klemm, Konstantin

**WOST (Workshop on Stochastic Thermodynamics), Vienna, Austria.**  
Manzano, Gonzalo

**Winter Workshop of Complex Systems.**  
Rosillo-Rodes, P.

**Complex satellite at the Conference on Complex Systems, Rome, Italy.**  
Rosillo-Rodes, P.

**SESAR Innovation Days 2025, Bled, Slovenia.**  
Zanin, Massimiliano

**22nd International Conference on Informatics and Information Technologies 2025, Struga, North Macedonia.**

Zanin, Massimiliano

**38th IEEE International Symposium on Computer-Based Medical Systems (CBMS), Madrid, Spain.**

Zanin, Massimiliano

**International School and Conference on Network Science 2025, Maastricht, the Netherlands.**

Zanin, Massimiliano

**Emerging Topics in Artificial Intelligence (ETAI) conference, SPIE. San Diego, CA, USA.**

Soriano, Miguel Cornelles

# 6

## CONFERENCES AND WORKSHOPS

7

OTHER  
ACTIVITIES

# 7 OTHER ACTIVITIES

## 7.1 PhD PROGRAM

---

IFISC participates in the PhD Program in Physics of the University of the Balearic Islands. During 2025, 54 PhD students developed their research project at IFISC, and 9 PhD thesis were completed and successfully defended:

**A Network Science approach to Human Interactions across Physical and Digital Spaces**

Arregui García, Beatriz (Supervisor: S. Meloni)

December 18

**Transport properties and induced superconductivity in magnetic topological insulators.**

Di Miceli, Daniele (Supervisors: Schmidt, Thomas L; Serra, Llorenç)

December 17

**An Agent-Based Journey in Social Systems Research: Motivations & Applications**

Moreno Lopez, Jesus A. (Supervisors: Ramasco, JJ & Meloni, S.)

December 11

**Structural Dynamics and Structure from Dynamics in Complex Ecosystems**

Sheykhali, Somaye (Supervisors: Eguiluz, V.M; Fernandez-Gracia, J.)

November 20

**Neocortical dynamics and computational mechanisms: integrating sensory and higher-order inputs**

Javier Galván Fraile (Supervisors: C. Mirasso and A. Arkhipov)

October 30

**Interacting particle systems with mobility and demographic dynamics as biological models**

Almodóvar Del Pozo, Alejandro (Supervisors: Galla, Tobias; López, Cristóbal)

July 29

**Spatiotemporal dynamics of coastal Mediterranean ecosystems**

Moreno-Spiegelberg, Pablo; (Supervisor: Gomila, Damià)

May 6

**An information-theoretic approach to higher-order Markov processes: Theory and applications**

De Gregorio, Juan (Supervisors: Toral, Raúl; Sánchez, David)

March 24

**Mathematical analysis of signed networks: structure and dynamics**

Diaz-Diaz, Fernando (Supervisors: Estrada, Ernesto; Meloni, Sandro)

January 22

## 7.2 SURF@IFISC

---

The Summer Undergraduate Research Fellowships (SURF@IFISC) program is part of IFISC's commitment to training future researchers in complex systems.

Since 2013, the program has offered undergraduate students from around the world the opportunity to gain their first experience in academic research under the supervision of an IFISC researcher. It is open to students in physics, mathematics, chemistry, biology, and engineering.

Each fellowship supports a four-week summer stay at IFISC, during which students carry out a research project guided by an IFISC mentor.

For the 2025 program, we received 43 applications from 22 universities across 7 different countries, with applicants representing 8 nationalities.

The program participants selected this year are the following seven students:

**Marc Rosendo Cerveró** from University of Valencia, Spain

**Alberto Mateos Roig** from University of Valencia, Spain

**Alvaro Iturbe Jabaloyes** from University of Granada, Spain

**Miguel Cerdán Ortuño** from University of Valencia, Spain

**Pau Rocabert** from Autonomous University of Barcelona, Spain

**Nuria Balbás** from Francisco de Vitoria University, Spain

**Ismaele Visentini** from University of Padova, Italy



### 7.3 IFISC MASTER

## IFISC Master in *Physics of Complex Systems*

<https://ifisc.uib-csic.es/master/>

In October 2012 IFISC started a Master program in Physics of Complex Systems. It is a one year (60 ECTS) official Master of the University of the Balearic Islands, in collaboration with CSIC. The courses provide an innovative entry point to Complex Systems fundamentals and applications and introduce the students in the research lines developed at IFISC. For the 2025-2026 academic course 22 students of 5 different nationalities are registered in the master.

In the year 2025, 9 master thesis were defended. They are listed in the Appendix of this Report.

This is the 2025-2026 Master syllabus:

Structural module courses (33 credits):

|  |                                   |
|--|-----------------------------------|
| Simulation methods (6 credits)                                   | P. Colet, R. Toral                |
| Cooperative and critical phenomena (6 credits)                   | E. Hernández-García, T. Sintes    |
| Dynamical systems, chaos and patterns (6 credits)                | D. Gomila, M. Matías              |
| Stochastic Processes (3 credits)                                 | P. Colet, R. Toral                |
| Complex Networks (3 credits)                                     | J. Fernández-Gracia               |
| Complex Quantum Systems (3 credits)                              | G. Giorgi, Ll. Serra, R. Zambrini |
| Introduction to data analysis and machine learning I (3 credits) | L. Lacasa                         |
| Information Theory (3 credits)                                   | D. Sánchez                        |

Specific module courses (9 credits minimum)

|   |                                       |
|---|---------------------------------------|
| Non equilibrium collective phenomena (3 credits)                  | C. López                              |
| Spatiotemporal dynamics (3 credits)                               | D. Gomila                             |
| Systems Biology (3 credits)                                       | M. Matías                             |
| Statistical Biophysics (3 credits)                                | T. Sintes                             |
| Modeling and dynamics of neural systems (3 credits)               | C. Mirasso                            |
| Complex Photonics (6 credits)                                     | A. Argyris, M. C. Soriano, I. Fischer |
| Open quantum systems (3 credits)                                  | R. Lopez, G. Manzano                  |
| Computational social sciences (6 credits)                         | P. Colet, J. Ramasco                  |
|   | D. Sanchez, M. Zanin, J. Fdez-Gracia  |
| Collective quantum phenomena (3 credits)                          | G. Giorgi, L. Serra                   |
| Quantum Information (3 credits)                                   | S. Ryu                                |
| Nonlinear phenomena in fluid flows and climate (3 credits)        | C. Lopez                              |
| Advanced complex networks (3 credits)                             | A. Fernandez Peralta                  |
| Ecology and population dynamics (3 credits)                       | T. Galla                              |
| Modeling based on complex systems in economics (3 credits)        | P. Colet, R. Lopez                    |
| Introduction to data analysis and machine learning II (3 credits) | M. C. Soriano, M. Zanin               |

Master thesis (12 credits)

Responsible: P. Colet

## 7.4 OTHER POSTGRADUATE COURSES

---

### Other Postgraduate Courses taught in 2025

The following courses were also taught in the **Master of Advanced Physics and Applied Mathematics**, University of the Balearic Islands:

- **Cooperative and critical phenomena (6 credits)**

Tomàs Sintès, Emilio Hernández-García

- **Stochastic simulation methods (6 credits)**

Pere Colet, Raúl Toral

- **Spintronics (3 credits)**

Rosa López, Llorenç Serra, David Sánchez

- **Electronic nanostructures (3 credits)**

David Sánchez, Llorenç Serra

The following courses were also taught in the **Master in Quantum Technologies**, International University Menendez Pelayo, Santander, Spain:

- **Quantum machine learning and computing (3 credits)**

Roberta Zambrini

- **Hybrid and Semiconductor Qubits (6 credits)**

Rosa Lopez

- **Open Quantum systems and Thermodynamics (3 credits)**

Gian Luca Giorgi, Rosa Lopez.

**7.5 MEMBERS OF EDITORIAL BOARD OF SCIENTIFIC JOURNALS****Mathematics.**

Estrada, Ernesto

**Frontiers in Physics.**

Apostolos Argyris  
 Lucas Lacasa  
 Cristóbal Lopez (editor)  
 Horacio Wio (associated editor)

**AppliedMath.**

Estrada, Ernesto

**Chaos: An Interdisciplinary Journal of Nonlinear Science.**

Fischer, Ingo (editorial advisory board)

**Proceedings of the Royal Society A.**

Giorgi, Gian Luca

**Ecological Complexity.**

Emilio Hernández García (member of the editorial advisory board)

**Complex Networks.**

Lacasa, Lucas

**Entropy.**

Lacasa, Lucas  
 Horacio Wio (associated editor)

**Frontiers in Complex Systems.**

Cristobal Lopez  
 Maxi San Miguel (field chief editor)

**European Physical Journal Special Topics.**

Pere Colet (member of the board of editors)

**European Physical Journal B.**

Wio, Horacio

**Physical Review Letters.**

Zambrini, Roberta (divisional associate editor)

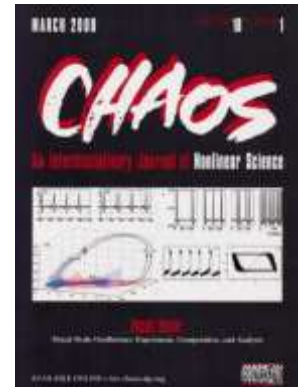

## 7.6 SCIENTIFIC COMMITTEES

---

- **Miguel Cornelles Soriano**

Program Committee Member of SPIE Photonics Europe - Semiconductor Lasers and Laser Dynamics. Estrasburgo, France.

Elected Member of IEEE Task Force on Reservoir Computing.

Elected member of the Quantum Optics and Nonlinear Optics Committee (SEDOPTICA).

- **Ingo Fischer**

Elected Member of IEEE Task Force on Reservoir Computing.

Member of the advisory board of the Japanese national project "Photonic Computing Highlighting Ultimate Nature of Light" (MEXT Grant-in-Aid for Transformative Research Areas). Tokyo, Japan.

- **Raúl Toral**

Member of the board of the C3 Division on Statistical Physics of the IUPAP.

Member of the board of the Division of Statistical Physics, Nonlinear and Complex Systems of the Spanish Royal Society.

- **Massimiliano Zanin**

ICT Innovations 2025, Ohrid, North Macedonia.

- **Gabor Drotos**

Member of the jury of Faculty conference of the Scientific Students' Association in physics at Eötvös Loránd University. Budapest, Hungary.

- **Lucas Lacasa**

Elected member of Spanish Association for Complex Systems CS3.

- **José J. Ramasco**

President Spanish Association for Complex Systems CS3.

- **Maxi San Miguel**

President Science of Mater and Energy (SME) Evaluation Committee. ESR/Equipex+ program, Agence National Recherche (ANR), France.

- **Tomás Sintés**

Member of the IUPAP Working Group on the Green Economy.

- **Roberta Zambrini**

Member representing Spain of the Quantum Community Network (QCN) of the European Quantum Flagship.

- **Manuel Matías**

Comité Científico FISES25. Santiago de Compostela, Spain

### **Awards and recognitions**

#### **Best Teacher Award for the Master in Physics of Complex Systems**

Raúl Toral and Pere Colet, IFISC

#### **Adjunct coordinator of the CSIC area of MATERIA.**

Ramasco, JJ

#### **CSIC coordinator for Physics.**

*Coordinador de area del CSIC para CT Fisicas.*

Ramasco, JJ

#### **Service Award Complex Systems Society.**

*Award for the services to the Society.*

Ramasco, JJ

#### **Elected as Fellow of Institute of Mathematics and its Applications (IMA) of the U. K.**

Estrada, Ernesto

#### **Elected Fellow of Network Science Society.**

Estrada, Ernesto

#### **Elected Corresponding Member of the Royal Academy of Sciences of Zaragoza.**

Estrada, Ernesto

#### **Elected Fellow of the International Core Academy of Sciences and Humanities.**

Estrada, Ernesto

### **7.7 RESEARCH STAYS IN OTHER CENTERS**

During 2025 IFISC Researchers visited 14 external research centers, 11 in Europe and 3 in the rest of the world.

These visits are listed in the Appendix to this Report.

# 7 OTHER ACTIVITIES

# 8

## OUTREACH ACTIVITIES

# 8

OUTREACH ACTIVITIES

Throughout 2025, IFISC maintained a strong commitment to bringing science closer to society by actively participating in a diverse outreach program. The following sections summarize the institute's participation in science fairs, school visits, gender equality initiatives, public lectures, and media engagements.

### 8.1 POSTER PARTY

---

The IFISC Poster Party is an annual event where PhD students and postdoctoral researchers at IFISC present their research in a poster format. In a relaxed atmosphere, attendees can learn firsthand about the work carried out by young researchers at IFISC. It is an excellent opportunity for undergraduate students to discover what a career in research involves, as they can interact directly with IFISC researchers and doctoral students who share their personal experiences and answer questions.



## 8.2 11F: INTERNATIONAL DAY OF WOMEN AND GIRLS IN SCIENCE

---

Within the framework of the International Day of Women and Girls in Science on February 11 (11F), Antònia Tugores participated in the round table “*Dones científiques a Mallorca*”. The event fostered discussion on gender perspectives in scientific careers, the challenges faced by women in research, and strategies to promote diversity and inclusion within academia and research institutions.

Also as part of the 11F activities, on February 12, Antònia Tugores took part in “*Científiques a l’aula*”, an initiative aimed at promoting female role models in science through direct engagement with school students. The activity emphasized the importance of visibility, representation and equal opportunities in STEM disciplines.

## 8.3 CIÈNCIA PER A TOTHOM

---

Between May 8 and 10, IFISC participated in *Ciència per a Tothom*, the largest science fair in the Balearic Islands. The event, organized annually by the University of the Balearic Islands (UIB), takes place over three days and is open to the general public, becoming a key meeting point between researchers and society. In addition to free public access, the program includes guided school visits, allowing primary and secondary students to explore scientific disciplines through structured activities adapted to different educational levels.



During the fair, IFISC staff Josu Blanco, Fernando Diaz, Juan Antonio Garcia, and Adrián García presented interactive demonstrations related to complex systems and statistical physics. Through hands-on experiments and informal yet rigorous explanations, visitors of all ages engaged with concepts such as emergence, collective behavior, and randomness. They experienced firsthand how simple interaction rules can generate rich, and sometimes unexpected, global dynamics.

#### 8.4 CIENTÍFIC@S EN PRÁCTICAS

---

During the week of May 26, IFISC participated in *Científic@s en prácticas*, an initiative designed to bring high school students closer to real research environments. Juan Fernández, Adrián García, Pere Colet, and Rosa López presented the fundamentals of research in complex systems and discussed academic and professional trajectories in the field of physics.

The session combined short talks with open discussions, allowing students to interact directly with researchers and obtain firsthand information about scientific practice. To conclude the activity, the students prepared a scientific poster summarizing the network research project they had been working on throughout the week.

On December 9, a new edition of the Scientists in Training program began. As their first activity, Juan Fernández and Adrián García visited IES Son Rullán and presented IFISC and the research carried out by its researchers to 9th grade students.

The session encouraged dialogue and direct interaction, reinforcing IFISC's commitment to inspiring future generations of scientists and encouraging them to participate in the next phases of the program.



### 8.5 NIT DE LA RECERCA

---

IFISC actively participated in *La Nit de la Recerca 2025*, one of the major science outreach events in the Balearic Islands.

At CaixaForum, “*Más allá de la computación: arte y juegos cuánticos*” was presented by Oriol Morguí Sancho, Manuel Miranda Barrado, Daniel Montesinos Capacete and Lucas Trigo García, exploring unconventional computing and quantum concepts through interactive and artistic approaches. This venue was organized by Fundación La Caixa.

At the venue organized by the Government of the Balearic Islands, the event began with the institutional opening, led by researcher Miquel Cornelles (IFISC, CSIC) and María Isabel Montserrat Sánchez (UIB), who spoke about artificial intelligence and how it is changing society.





Throughout the afternoon, attendees were able to visit the research fair, where IFISC invited the public to discover the hidden mechanisms behind seemingly everyday phenomena. Visitors experimented with a chaotic pendulum, observed the real-time synchronization of metronomes, and were surprised by an optical illusion involving ambiguous cylinders, simple but powerful examples of how physics helps us understand the complexity of the natural world.

Finally, as part of the micro-lecture program “Science Takes the Stage”, IFISC researcher Ruben Herzog gave a talk entitled *Psychedelic Medicine: New Frontiers in Mental Health*, an introduction to an emerging and interdisciplinary field that combines neuroscience, physics, and data science to explore new avenues in mental health.



## 8.6 OTHER OUTREACH ACTIVITIES

### Scholar visits

On March 14, IFISC hosted students from Colegio Natzaret. The visit included presentations by Juan A. García, Josu Blanco, Annalisa Caligiuri, Pablo Rosillo, David Jiménez, Moritz Plüger and Adrián García.

Students were introduced to IFISC's research areas, laboratory facilities and computational infrastructure. The session provided an overview of how theoretical models, data analysis and high-performance computing are applied to the study of complex systems, offering a realistic insight into research activity at the institute.

### IX Jornada d'orientació vocacional

On May 9, Adrián García represented IFISC at the *IX Jornada d'orientació vocacional*, an event focused on academic guidance for secondary school students. The session addressed university pathways in physics and interdisciplinary research, as well as professional opportunities within academia and industry.

The activity, organized by the Centro Universitario de Calvià, aimed to provide clear and motivating perspectives on scientific careers, emphasizing quantitative reasoning, analytical skills and curiosity-driven research.

### Databeers

As part of the Databeers outreach series, Juan de Gregorio delivered a public talk entitled "*Relaciones lingüísticas a través de la sintaxis y la proximidad geográfica*", presenting research on syntactic similarities across contemporary languages. The event, held in Valencia, engaged a broad audience in exploring how linguistic structures relate to geographic proximity and shared cultural histories.

### Science fair ¡Cuánto talento!

On March 27, outreach technician Adrián García participated in the outreach event “¡Cuánto talento!” in Fuerteventura, Canary Islands. The activity was aimed at showcasing scientific and creative talent among young students, highlighting the value of interdisciplinary thinking and the connections between science, creativity and culture.

The session illustrated how physics and complex systems theory can be communicated through innovative and engaging formats, encouraging students to explore science beyond traditional academic frameworks.

### Best Teacher Award for the Master in Physics of Complex Systems

On September 15, Raúl Toral and Pere Colet received the Best Teacher Award for the Master in Physics of Complex Systems. This distinction highlights IFISC’s commitment to excellence in postgraduate education and the strong integration between research and advanced teaching within the institute.



In addition, they delivered an outreach lecture on computational methods in stochastic systems, presenting key numerical and analytical approaches used to model noise-driven dynamics and probabilistic processes in complex physical systems.

### CSIC Semana de la Ciencia

On November 11, Adrián García delivered the outreach talk “De las hormigas al heavy metal: cómo la ciencia explica el desorden del mundo”. The lecture took place at the CSIC headquarters in Madrid as part of the Semana de la Ciencia program and was organized by the editorial Anaya. It explored how concepts from complex systems theory help explain collective behavior, emergence, and apparent disorder across biological, cultural, and social domains.

The activity combined scientific rigor with an accessible narrative approach, emphasizing the interdisciplinary scope of modern physics and its capacity to interpret complex phenomena in nature and society.

## 8.7 PRESS AND MEDIA

News about IFISC and its research results are regularly posted in the 'News' section of the web site: <https://ifisc.uibcsic.es/en/news/>

IFISC research has also received attention from newspapers and other media. During 2025, IFISC activities produced 113 press releases and appearances in written and digital press (national and international), and 15 clips on radio and TV. See the full lists in the Appendix.

## Físicos buscan la tecnología del futuro: ordenadores de fotones, más rápidos y menos contaminantes

Un equipo internacional de investigadores, liderado desde España, estudia utilizar la luz para sustituir los sistemas digitales en el procesamiento de datos, lo que reduciría la huella de carbono.

— Nuevos datos revelan que la actividad solar no deja de aumentar y los científicos no saben por qué

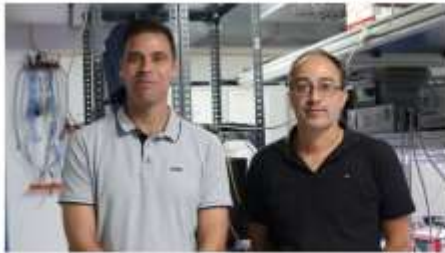

Los investigadores Miguel C. Soriano y Apollonio Argente en el laboratorio de física del IFISC. Imagen por Miguel C. Soriano.



## La megafauna marina existe, no hemos buscado donde correspondía

Esa es la conclusión de un estudio internacional realizado por unos 400 científicos de más de 50 países.



Physics Mathematics Biology Computer Science Topics Archive



MATHEMATICAL BIOLOGY

## The 'Elegant' Math Model That Could Help Rescue Coral Reefs

📖 | 📄

Physicists and marine biologists built a quantitative framework that predicts how coral polyps collectively construct a variety of coral shapes.



CONSTANTES Y VITALES



Actualidad

Mujeres científicas

Las clases de la Brújula

Menos cuento, más ciencia

Salud Mental

Podcasts

CONSTANTES Y VITALES ACTUALIDAD

DETECCIÓN GRIPE Y COVID-19



## 'Epidemiradar' es la nueva herramienta del CSIC que convierte a la ciudadanía en aliada contra la gripe y la covid-19

El CSIC lanza "Epidemiradar", una plataforma online que invita a la ciudadanía a informar semanalmente sobre su estado de salud para mejorar el seguimiento de la gripe, la covid-19 y otras enfermedades respiratorias en España, mezclando ciencia y participación de la ciudadanía.

8.8 SOCIAL MEDIA IMPACT SUMMARY



**TWITTER @IFISC\_mallorca**

Total Followers 3.343



**<http://www.facebook.com/ifisc>**

Facebook fans: 1.129

61% men / 39% women

Mostly located in Spain, Brazil and Mexico



**<http://www.youtube.com/user/IFISCseminars>**

Visualizations: 25.463 in 2025 of a total of 355.948

YouTube subscribers: 3.567

85% men / 15% women

Mostly located in Spain, USA, Mexico, India and Colombia



**<https://www.linkedin.com/company/ifisc-institute-for-cross-disciplinary-physics-and-complex-systems-csic-uib->**

Total Followers: 1.373



**<https://bsky.app/profile/ifisc.uib-csic.es>**

Total followers: 514

# 8

OUTREACH ACTIVITIES

# APPENDIX



## a.4. IFISC seminars and talks 2025

In the electronic version of this report, titles are hyperlinked to the recording of the seminar, if available.

December 18  
**A Network Science approach to Human Interactions across Physical and Digital Spaces**  
 Beatriz Arregui García, IFISC

December 17  
**Simple models for a complex world: Finding statistical laws in the dynamics of sociality**  
 Gerardo Iñiguez, Faculty of Information Technology and Communication Sciences, Tampere University, Finland and Department of Network and Data Science, Central European University, Vienna

December 17  
**Rhythmic Coordination in a Network of Interacting Brain Pathways**  
 Dimitrios Chalkiadakis, IFISC

December 16  
**Ecomeeting - December 2025: Thermodynamics vs. Natural Selection and Algorithmic Chemistry of the Origin of Life.**  
 Giampaolo Folena, IFISC

December 11  
**Thermodynamic Uncertainty Relation in Hybrid Normal-Superconducting Systems: The Role of Superconducting Coherence**  
 Michele Governale, School of Chemical and Physical Sciences and MacDiarmid Institute for Advanced Materials and Nanotechnology, Victoria University of Wellington, New Zealand

December 11  
**An agent based journey in social systems research: motivations & applications**  
 Jesus Moreno Lopez, IFISC and FBK, Trento, Italy

December 10  
**Topological insulator phases in 2D materials**  
 Vassilios Vargiamidis, IFISC

December 9  
**Científic@s en prácticas**  
 Juan Fernández, Adrián García, IFISC

December 9  
**Neuroplasticity-Driven Stroke Rehabilitation: Validating Motor Imagery with fNIRS and Aphasia Evaluation via Functional Connectivity Analysis**  
 John Q. Fang, Shantou University, China.

December 9  
**Stochastic field effects in the Ising model: symmetry breaking and symmetry restoring**  
 Sara Oliver-Bonafoux, IFISC

December 3  
**Criticality and Hierarchy of Temporal Dynamics in the Human Brain**  
 Kaichao Wu, IFISC

November 25  
**Friends, Foes, and Factions: The Math Behind Signed Networks**  
 Fernando Diaz Diaz, Applied Mathematics, University Carlos III of Madrid, Spain

November 24  
**The effect of temporal variability on species interactions and community assembly**  
 Violeta Calleja Solanas, Estación Biológica de Doñana, Spain

November 21  
**Synchronization in coupled laser networks**  
 Adam César Mackowiak Pellón, IFISC

November 20  
**How do cells count? Signals, networks, and cell ratios**  
 Adrián Jacobo, Chan-Zuckerberg BioHub, Chicago, USA

November 20  
**Thesis defense: Structural Dynamics and Structure from Dynamics in Complex Ecosystems**  
 Somaye Sheykhali, IFISC

November 20  
**Praderas marinas: Evaluación de riesgo con drones e IA**  
 Daniel Ruiz-Reynés, IFISC

November 11, 18 and 25  
**Sociomeeting: Short Course - Hybrid Collective Intelligence of Humans and Machines (day 2)**  
 Taha Yasseri, Trinity College Dublin, Ireland

November 12  
**An algorithmic perspective on the origin of life**  
 Giampaolo Folena, IFISC

November 11  
**Stochastic Unravelling of Open Quantum System Dynamics Governed by Correlated Noise**  
 Pietro de Checchi, Department of Mathematics, University of Padova, Italy

October 30  
**Neocortical dynamics and computational mechanisms: Integrating sensory and higher-order inputs**  
 Javier Galván Fraile, IFISC

October 29  
**Eco-evolutionary constraints shape the endemicity and epidemic trajectories of rapidly evolving viruses**  
 David Soriano-Paños, Universitat Rovira i Virgili of Tarragona, Spain

October 28  
**Deep-learning-assisted simulation of a cortical circuit: Integrating anatomy, physiology and function**  
 Shinya Ito, Allen Institute for Brain Science, Washington, USA

October 22  
**The Paradox of Openness: Community-Based Approaches to Combating Misinformation Online**  
 Taha Yasseri, Trinity College Dublin, Ireland

October 15  
**50 years of frustration: a personal summary**  
 Tobias Galla, IFISC

October 13  
**Quantum dynamics of Solitons in a relativistic field equation**  
 Joan Cucurull, IFISC

October 8  
**Reservoir computing in photonic integrated circuits**  
 Mohab Abdalla, CentraleSupélec, Paris, France

- October 7  
**Sociomeeting: The structure of global delay propagation in air transport**  
Josu Blanco, IFISC
- October 7  
**The structure of global delay propagation in air transport**  
Josu Blanco, IFISC
- October 6  
**Synoptic quantum many body methodology of correlated electron systems**  
Ronny Thomale, University of Würzburg, Germany
- October 1  
**MdM Quantum meeting: Flatband phenomena and Quantum Geometry in correlated electron systems**  
Ronny Thomale, University of Würzburg, Germany
- September 30  
**Quantum adiabatic computation via bifurcation for solving combinatorial problems**  
Pablo Gallardo Calleja, IFISC
- September 29  
**Reduced Intrinsic Neural Timescales in Schizophrenia during Predictive Coding**  
Sergio Zucchi, IFISC
- September 26  
**How interactions and connectivity in social media networks mediate language use**  
David Mateo Carpio Rivas, IFISC
- September 26  
**Neural Networks in Deep Quantum-Classical Architectures**  
Mateu Coll Comas, IFISC
- September 24  
**Developing Mathematical and Physical Tools for Multiscale Dynamical Systems: Applications to Neurophysiological Data.**  
Diego Mateos, Consejo Nacional de Investigaciones Científicas y Técnicas (CONICET), Argentina; Achucarro Basque Center for Neuroscience, País Vasco, Spain
- September 19  
**Large Deviation Full Counting Statistics in Adiabatic Open Quantum Dynamics**  
Paulo Jose Paulino de Souza, IFISC
- September 4  
**Dynamics of complex communities with random, structured interactions**  
Silvia De Monte, Institute of Biology of École Normale Supérieure in Paris, France, and Max Planck Institute for Evolutionary Biology, Germany
- July 30  
**Cell Tissue Dynamics due to Topological Changes and Fluidisation**  
Luiza Angheluta,, Department of Physics, University of Oslo, Norway
- July 29  
**Interacting particle systems with mobility and demographic dynamics as biological models**  
Alejandro Almodóvar del Pozo, IFISC
- July 28  
**Ecological systems are rarely well-mixed: how movement behavior determines spatial structure and shapes ecological processes**  
Ricardo Martinez-Garcia, Center for Advanced Systems Understanding (CASUS), Helmholtz-Zentrum Dresden-Rossendorf (HZDR), Germany
- July 28  
**Monitoring the Resilience of Seagrass Meadows from Satellite Meadows from Satellite Imagery Using Machine Learning**  
Elena del Campo, IFISC
- July 22  
**Quantum reservoir computing with metastable dynamics**  
Albert Cañellas García, IFISC
- July 17  
**The unreasonable effectiveness of mathematics in the natural sciences**  
All participants (facilitated by Tobias Galla), IFISC
- July 10  
**Geometric influences on brain function and regional organization**  
James Pang, Neural Systems and Behaviour Lab, School of Psychological Sciences, Monash University, Australia
- July 8  
**Sociomeeting: Congestion in Traffic Systems - A Statistical Physics Perspective**  
Alberto Amaduzzi, Fondazione Bruno Kessler, Trento, Italy
- July 4  
**Always on my mind-tuning: The intuition mechanism**  
Lluís Arola Fernández, IFISC
- July 3  
**Designing Quantum Sensors via Randomness**  
Sai Vinjanampathy, IIT Bombay
- July 1  
**Sociomeeting: An exploration of Lexical Patterns in APS Journals**  
Fernanda Sánchez Puig, UNAM, Mexico
- June 26  
**Annual Ph. D. control talks on quantum topics part II**  
Jorge García-Beni; Adrià Labay-Mora; Antonio Sannia, IFISC
- June 26  
**MdM Quantum meeting: Hybrid interacting quantum Hall thermal machine**  
Sara Finocchiaro, University of Insubria, Italy
- June 25  
**Bayesian Machine Learning in practice**  
Ezequiel Alvarez, ICAS (International Center for Advanced Studies), Buenos Aires, Argentina
- June 25  
**Annual Control: Protection of Marine Megafauna mediated by Exclusive Economic Zones**  
Gorka Buenvarón-Campo, IFISC

- June 25  
**Characterizing upper ocean variability near Ibiza and Formentera: A comparative analysis of clustering techniques**  
Victor Rodriguez-Mendez, NielsenQ, Chicago, USA
- June 24  
**Modeling the effect of temperature on vector-borne diseases**  
Juan Carlos Rodríguez Cabanillas, IFISC
- June 20  
**Modelling carbon dynamics in Lagrangian oceanic ecosystems: applications to the SOIREE fertilization experiment**  
Stefano Campagnola, IFISC
- June 20  
**Annual Ph. D. control talks on quantum topics**  
Daniel Montesinos; Guillem Llodrà; Marta Gili, Oriol Morguí, IFISC
- June 18  
**Training the Untrainable: Learning to backpropagate through spikes and time**  
Javier Galván, IFISC
- June 17  
**SINDyPy workshop**  
Manuel Miranda, IFISC
- June 17  
**Keep your files tidy: tidypath organizes your research data automatically**  
Jorge Medina, IFISC
- June 17  
**The learning-chaos trade-off in neural network training**  
Pedro Jiménez, IFISC
- June 16  
**IFISC x FisEs25**  
FisEs'25 participants, IFISC (UIB-CSIC)
- June 16  
**Exploring delay propagation in air transport using temporal networks**  
Pau Esteve, IFISC
- June 12  
**Analysis of Large Financial Correlation Matrices**  
Laia Palacín, IFISC
- June 11  
**MdM Quantum meeting: Certifying quantum enhancements in thermal machines beyond the Thermodynamic Uncertainty Relation**  
Jose A. Almanza-Marrero, IFISC
- June 9  
**Ecomeeting: 3D habitat mapping and automated video analysis of the invasive spider crab *Percnon gibbesi* in the Mediterranean Sea**  
Andrea Anton, Silvia Paoletti, Hilmar Hinz & Nuria Marbà, IMEDEA, Spain
- June 4  
**Just when you thought you knew everything about Fractal Aggregates**  
Amitabha Chakrabarti, Department of Physics, Kansas State University, Manhattan (KS), USA
- June 3  
**Excitable dynamics and coral reef formation: A simple model of macro-scale structure development**  
Miguel Álvarez, IFISC
- June 3  
**Lagrangian and Eulerian data processing for LAMARCA**  
Alberto Baudena, ISMAR-CNR, Lerici, Italy
- May 29  
**Fusing urban modelling and urban computation: from active population to urban scaling laws**  
Ruiqi Li, Hangzhou International Innovation Institute, Beihang University, Pekin, China
- May 29  
**Rank aggregation methods in Network Meta-Analysis**  
Paride Crisafulli, IFISC
- May 27  
**Sociomeeting: Temporal networks as time series, high vs low dimensional representations**  
Lucas Lacasa, IFISC
- May 26  
**Cientific@s en prácticas**  
Juan Fernández, Adrián García, Pere Colet, Rosa López, IFISC
- May 23  
**Ecomeeting: Complexity-Stability of Ecological Communities: Empirical Evidence and the Role of Population Structure**  
Àlex Giménez Romero, CEAB – CSIC, Spain
- May 21  
**Fantastic Simulation of Social Systems and Where to Find Them**  
Francesco Bertolotti, LIUC - Università Cattaneo, Italy
- May 20  
**Sociomeeting: LLM-enhanced Agent-Based Models, a Methodological Discussion Based on Three Applications**  
Francesco Bertolotti, LIUC - Università Cattaneo, Italy
- May 16  
**Introducing infomeasure: a comprehensive Python package for information theory measures and estimators**  
Carlson Moses Büth, IFISC
- May 13  
**Sociomeeting: Complex Systems Approaches to Crime**  
Dario Zarcone, Università degli studi di Palermo, Italy
- May 9  
**The 28th April blackout: Background on power-grid dynamics from a complex-systems perspective**  
Pere Colet, IFISC
- May 8  
**Equity committee open meeting**  
Roberta Zambrini, Juan Fernández-Gracia, IFISC
- May 6  
**"The end of theory" -- A debate**  
Juan Fernández Gracia vs Tobias Galla, IFISC
- May 6  
**Spatiotemporal dynamics of coastal Mediterranean ecosystems**  
Pablo Moreno-Spiegelberg, IFISC
- April 30  
**The Role of Machine Learning Copies in Ensuring a More Trustworthy AI**  
Jordi Nin, Esade Business School, Ramon Llull University, Catalunya, Spain

April 29

**Sociomeetings journal club: do not write your CV as a man and you will earn as much as a man**  
Pablo Rosillo-Rodes, IFISC

April 16

**Effective and Fast Learning for Neuromorphic Hardware**  
Robert Legenstein, Institute of Machine Learning and Neural Computation, Graz University of Technology, Austria.

April 15

**Ecomeeting: Unraveling an ecological interaction measure: What models teach us and what they learn in return.**  
Javier Aguilar, Laboratory of Interdisciplinary Physics, University of Padova, Italy

April 10

**Cooperation within and between species: the effects of spatial structure**  
Christoph Hauert, Department of Mathematics, The University of British Columbia, Vancouver, Canada

April 7

**Workshop on the Evoludo software for agent-based simulations**  
Christoph Hauert, University of British Columbia, Vancouver, Canada

March 28

**Mechanical proofs of the second law: ergotropy and passive states**  
Juan MR Parrondo, GISC and Universidad Complutense de Madrid, Spain

March 25

**Sociomeetings journal club: Sloppy Models. Why (Almost) Every Model Has Too Many Parameters**  
Fernando Díaz-Díaz, IFISC

March 24

**Exploring Mild Cognitive Impairment Data Using Symbolic Information Approaches**  
Graça Regina Mata de Almeida, Universidade Federal de Alagoas, Brasil

March 24

**An information-theoretic approach to higher-order Markov processes: theory and application**  
Juan de Gregorio, IFISC

March 19

**Spatial heterogeneity accelerates phase-to-trigger wave transitions in frog egg extracts**  
Daniel Ruiz Reynolds, IFISC

March 18

**Sociomeeting: Applying stochastic thermodynamics to a social imitation-differentiation model**  
Gonzalo Manzano, IFISC

March 14

**Scientists must write, and they must try to do it well**  
Tobias Galla, IFISC

March 12

**A scalable 2-local architecture for quantum annealing of all-to-all Ising models**  
Ana Palacios, Qilimanjaro, Barcelona, Spain

March 11

**Using Statistical Measures from Causal Information Theory to Characterize Sleep Stages in Human Intracranial Data**  
Helena Bordini de Lucas, IFISC & Universidade Federal de Alagoas, Brazil

March 11

**Sociomeeting: Universal Statistics of Competition in Democratic Elections**  
Aanjaneya Kumar, Santa Fe institute, NM, USA

March 11

**MdM Quantum meeting: A single superconducting vortex on a leash: Thermodynamics and applications**  
Maciej Zgirski, Institute of Physics, Polish Academy of Science, Poland

March 5

**Parameter estimation with an entangled time-crystal phase**  
Robert Mattes, University of Tübingen, Germany

March 5

**Parameter estimation using the emitted light of a collective atomic system**  
Albert Cabot, University of Tübingen, Germany

March 4

**Sociomeeting: barometer of the CS3 and project presentation**  
Pablo Rosillo-Rodes, Jesús Moreno, IFISC

February 28

**Memory-minimal quantum generation of stochastic processes**  
Magdalini Zonnios, Trinity College Dublin, College Green, Dublin, Ireland

February 21

**Study of a Lotka Volterra dynamics with random carrying capacities**  
Carlotta Nunzi, IFISC

February 20

**MdM Quantum meeting: Quantum Thermodynamics in Gdansk and catalytic effects in Otto-like quantum heat engines**  
Michal Horodecki, University of Gdansk, Poland

February 19

**Thermodynamics of Bose condensation in nonequilibrium quantum gases**  
Luisa Toledo, IFISC

February 18

**The Role of Inhibitory Neuronal Heterogeneity in Phase Relations Between Cortical Networks.**  
Katiele Brito, Federal University of Alagoas, Brazil

February 13

**Collegiality Meeting**  
Lucas Lacasa, IFISC

February 12

**Inequality in an agent based model of capitalism**  
Celia Anteneodo, Department of Physics, PUC-Rio, Rio de Janeiro, Brazil

February 11

**Sociomeeting: 2025 Kickoff**  
Various speakers, IFISC

January 24  
**Characterising the dynamics of unlabelled temporal networks**  
 Annalisa Caligiuri, IFISC

January 22  
**Mathematical Analysis of Signed Networks: Structure and dynamics**  
 Fernando Díaz Díaz, IFISC

January 16  
**Anticipated synchronization with distributed delay**  
 David Ortiz, IFISC

## a.5. Publications

In the electronic version of this report, titles are hyperlinked to the summary and PDF file of the publications

### a.5.1 Indexed Publications

**Global tracking of marine megafauna space use reveals how to achieve conservation targets**

*Sequeira, Ana M.M.; Rodríguez, Jorge P.; Eguiluz, Victor M.*  
 Science 388, 6751

**How spatiotemporal dynamics can enhance ecosystem resilience**

*Moreno-Spiegelberg, Pablo; Rietkerk, Max; Gomila, Damià*  
 Proceedings of the National Academy of Sciences of the USA (PNAS) 122, e2412522122

**Designing Open Quantum Systems for Enabling Quantum-Enhanced Sensing through Classical Measurements**

*Mattes, Robert; Cabot, Albert; Carollo, Federico; Lesanovsky, Igor*  
 Physical Review Letters 135, 230402

**Erratic non-Hermitian skin localization**

*Longhi, Stefano*  
 Physical Review Letters 134, 134, 196302 (1-7)

**Nonlinear Non-Hermitian Skin Effect and Skin Solitons in Temporal Photonic Feedforward Lattices**

*Wang, Shulin; Wang, Bing; Liu, Chenyu; Qin, Chengzhi; Zhao, Lange; Liu, Weiwei; Longhi, Stefano; Lu, Peixiang*  
 Physical Review Letters 134, 243805 (1-7)

**Gambling Carnot Engine**

*Tohme, Tarek; Bedoya, Valentina; di Bello, Costantino; Bresque, Léa; Manzano, Gonzalo; Roldán, Édgar*  
 Physical Review Letters 135, 06710

**On-Demand and Tunable Andreev-Conversion of Single-Electron Charge Pulses**

*Burset, Pablo; Roussel, Benjamin; Moskalets, Michael; Flindt, Christian*  
 Physical Review Letters 135, 246303

**Women for Quantum: Manifesto of Values**

*Women for Quantum, including Zambrini, Roberta.*  
 Communications Physics 8, 422 (1-3)

**Flow spatial structure determines pattern instabilities in nonlocal models of population dynamics**

*Silvano, Nathan O. ; Valeriano, João; Hernández-García, Emilio; López, Cristóbal; Martínez-García, Ricardo*  
 Communications Physics 8, 326 (1-12)

**Mapping and modeling age-related changes in intrinsic neural timescales**

*Wu, Kaichao; Gollo, Leonardo L.*  
 Communications Biology, 8 (1), p.167

**Transmission grid stability with large interregional power flows**

*Martínez-Barbeito, María; Gomila, Damià; Colet, Pere; Fritzsche, Julian; Jacquod, Philippe*  
 Physical Review Research 7, 013137

**Wigner's friend scenarios: on what to condition and how to verify the predictions**

*del Santo, Flavio; Manzano, Gonzalo; Brukner, Caslav*  
 Physical Review Research 7, 033279

**Excitable dynamics and coral reef formation: A simple model of macro-scale structure development**

*Álvarez-Alegría, Miguel; Moreno-Spiegelberg, Pablo; Matias, Manuel A; Gomila, Damià*  
 Physical Review Research 7, 023196 (1-15)

**Entropy and type-token ratio in gigaword corpora**

*Rosillo-Rodes, Pablo; San Miguel, Maxi; Sanchez, David*  
 Physical Review Research 7, 033054 (1-14)

**Solitons, chaos, and quantum phenomena: a deterministic approach to the Schrödinger equation**

*Gomila, Damià*  
 Physical Review Research 7, 033276

**Thermodynamic uncertainty relations in superconducting junctions**

*Ohnmach, David Christian; Cuevas, Juan Carlos; Belzig, Wolfgang; López, Rosa; Lim, Jong Soo; Kim, Kun Woo.*  
 Phys. Rev. Research, 7, L012075

**Entanglement generation and stabilization by coherent collisions**

*Bozkurt, A. Mert; López, Rosa; Ryu, Sungguen*  
 Physics Review Research 7, 013145

**Conditional fluctuation theorems and entropy production for monitored quantum systems under imperfect detection**

*Ferri-Cortés, Mar; Almanza-Marrero, José A.; López, Rosa; Zambrini, Roberta; Manzano, Gonzalo*  
 Phys. Rev. Research 7 (1), 013077

**Existence of unbiased estimators in discrete quantum systems**

Navarro, J.; Ravell Rodríguez, Ricard.; Sanz, M.  
Phys. Rev. Research 7, 023060

**Information decomposition of airport dynamics: A study of Europe and US**

Acharya, Kishor; Zanin, Massimiliano  
Transportation Research Interdisciplinary Perspectives 31, 101466

**Temperature stabilization with Hebbian learning using an autonomous optoelectronic dendritic unit**

Ortín, Silvia; Pflüger, Moritz; Argyris, Apostolos  
Springer Nature Frontiers of Optoelectronics 18, 7 (1-12)

**What is a proper graph Laplacian? An operator-theoretic framework for graph diffusion.**

Estrada, Ernesto  
Special Matrices 13 (1), 20250047

**Balance with Memory in Signed Networks via Mittag-Leffler Matrix Functions**

Tian, Y.; Estrada, E.  
SIAM Journal on Matrix Analysis and Applications 46, 1460-1483

**Network Efficiency under Nonconservative Diffusion**

Azemar, A.; Estrada, E.  
SIAM Journal on Applied Dynamical Systems 24, 1378-1407

**Entropy, Irreversibility, and Time-Series Deep Learning of Kinematic and Kinetic Data for Gait Classification in Children with Cerebral Palsy, Idiopathic Toe Walking, and Hereditary Spastic Paraplegia**

de Gorostegui, Alfonso; Zanin, Massimiliano; Martín-Gonzalo, Juan-Andrés; López-López, Javier; Gómez-Andrés, David; Kiernan, Damien; Rausell, Estrella  
Sensors 25 (13), 4235

**Deep Learning Unravels Differences Between Kinematic and Kinetic Gait Cycle Time Series from Two Control Samples of Healthy Children Assessed in Two Different Gait Laboratories**

De Gorostegui Álvarez de Miranda, Alfonso; Kiernan, Damien; Martín-Gonzalo, Juan-Andrés; López-López, Javier; Pulido-Valdeolivas, Irene; Rausell, Estrella; Zanin, Massimiliano; Gómez-Andrés, David  
Sensors 25, 110

**Knowledge-dependent optimal Gaussian strategies for phase estimation**

Ravell Rodríguez, Ricard; Morelli, Simon  
SciPost Phys. 18, 167

**Unveiling the drivers of active participation in social media discourse**

Baqir, Anees; Chen, Yijing; Diaz-Diaz, Fernando; Kiyak, Sercan; Louf, Thomas; Morini, Virginia; Pansanella, Valentina; Torricelli, Maddalena; Galeazzi, Alessandro  
Scientific Reports 15, 4906

**infomeasure: a comprehensive Python package for information theory measures and estimators**

Büth, Carlson M.; Acharya, Kishor; Zanin, Massimiliano  
Scientific Reports 15, 29323

**High-resolution climate data reveals increased risk of Pierce's Disease for grapevines worldwide**

Giménez-Romero, Àlex; Moralejo, Eduardo; Matías, Manuel A.  
Scientific Reports 15, 31282 (1-12)

**Critical mobility in policy making for epidemic containment**

Moreno López, J.A.; Mateo, D.; Hernando, A.; Meloni, S.; Ramasco, JJ  
Scientific Reports 15, 3055

**On the limits of the intervention on complex systems guided by functional networks**

Zanin, Massimiliano  
Scientific Reports 15, 22304

**Multilayer networks describing urban interactions for building the digital twins of five cities in Spain**

Rodríguez, JP, Aleta, A, Moreno, Y.  
Scientific Data 12, 1227

**Theoretical framework for quantum associative memories**

Labay-Mora, Adrià; Fiorelli, Eliana; Zambrini, Roberta; Giorgi, Gian Luca  
Quantum Science and Technology 10, 035050 (1-30)

**Thermodynamics of coupled time crystals with an application to energy storage**

Paulino, Paulo J.; Cabot, Albert; De Chiara, Gabriele; Antezza, Mauro; Lesanovsky, Igor; Carollo, Federico  
Quantum Science and Technology, 11, 015003

**Mpemba effect and super-accelerated thermalization in the damped quantum harmonic oscillator**

Longhi, Stefano  
Quantum 9, 1677 (1-23)

**Certifying quantum enhancements in thermal machines beyond the Thermodynamic Uncertainty Relation**

Almanza-Marrero, José A.; Manzano, Gonzalo  
Quantum 9, 1878

**An Efficient Quantum Algorithm for the Traveling Salesman Problem**

Sharma, A.; Deshpande, N.; Ghosh, S.; Das, S.; Roy, S.  
Quantum Information & Computation Volume 25, pp. 71–81

**A large-scale data set of aircraft interaction networks**

López-Martín, Raúl; Zanin, Massimiliano  
PLOS One 20, e0336909

**The role of feedforward and feedback inhibition in modulating theta-gamma cross-frequency interactions in neural circuits**

Chalkiadakis, D.; Sánchez-Claros, J.; López-Madróna, V. J.; Canals, S.; Mirasso, C. R.  
PLoS Computational Biology 21, e1013363

**Inferring leader-follower behavior from presence data in the marine environment: A case study on Reef Manta Rays**

*Fernández-Gracia, Juan; Rodríguez, Jorge P.; Peel, Lauren R.; Klemm, Konstantin; Meekan, Mark G.; Eguíluz, Víctor M.*  
PLOS Complex Systems 2, e0000073

**A systematic review of ecosystem services analysis and network theory**

*Casali, Ylenia; Balbi, Stefano; Eguíluz, Víctor M.*  
PLOS Complex systems 2, e0000054

**Disruption of outdoor activities caused by wildfire smoke shapes circulation of respiratory pathogens**

*Arregui-García, B.; Ascione, C.; Pera, A.; Wang, B.; Stocco, D.; Carlson, C.J.; Bansal, S.; Valdano, E.; Pullano, G.*  
PLOS Clim 4(6): e0000542.

**Transfer learning-enhanced deep reinforcement learning for aerodynamic airfoil optimisation subject to structural constraints**

*Ramos, David; Lacasa, Lucas; Valero, Eusebio; Rubio, Gonzalo*  
Physics of Fluids 37, 8

**Complex networks approach to curriculum analysis and subject integration: A case study on physics and mathematics**

*Tuzón, Paula; Salvà Salvà, Antoni; Fernández-Gracia, Juan*  
Physical Review Physics Education Research 21, 010161

**Analysis of a voter model with an evolving number of opinion states**

*Choi; Jeehye; Min, Byungjoon Min; Galla, Tobias*  
Physical Review E 111, 064303

**Generalized correlations in disordered dynamical systems: Insights from the many-species Lotka-Volterra model**

*Castedo, Sebastian H.; Holmes, Joshua; Baron, Joseph W.; Galla, Tobias*  
Physical Review E 111, 044202

**Interaction networks in persistent Lotka-Volterra communities**

*Poley, Lyle; Galla, Tobias; Baron, Joseph W.*  
Physical Review E 111, 014318

**Thermodynamic inference in molecular motors: A martingale approach**

*Nadal-Rosa, Adrián; Manzano, Gonzalo*  
Physical Review E 112, 034114

**Competition between group interactions and nonlinearity in voter dynamics on hypergraphs**

*Kim, Jihye; Lee, Deok-Sun; Min, Byungjoon; Porter, Mason A.; San Miguel, Maxi; Goh, K.-I.*  
Physical Review E 111, L052301

**Modelling echo chamber effects in signed networks**

*Vendeville, Antoine; Diaz-Diaz, Fernando*  
Physical Review E 111, 024302

**Comparing temporal and aggregated network descriptions of fluid transport in the Mediterranean Sea**

*Acharya, Kishor; Aguilar, Javier; Dall'Amico, Lorenzo; Nicolaou, Kyriacos; Meloni, Sandro; Ser-Giacomi, Enrico*  
Physical Review E 111, 024211

**Navigating uncertainty: Risk-averse versus risk-prone strategies in populations facing demographic and environmental stochasticity**

*Calvo, Rubén; Muñoz, Miguel Angel; Galla, Tobias*  
Physical Review E 111, 024118

**Cyclical oscillations and absorbing-state probabilities in optional public goods games: Interplay of reward and group size**

*Stock, E.V.; Valverde, P.; González-Avella, J.C.; Iglesias, J.R.; Gonçalves, S.; Da Silva, R.*  
Phys. Rev. E 111, 014138

**Analytic and Monte Carlo approximations to the distribution of the first-passage time of drifted diffusion with stochastic resetting and mixed boundary conditions,**

*Magalang, J.; Turin, R.; Aguilar, J.; Colombani, L.; Sanchez-Taltavull, D.; Gatto, R.*  
Phys. Rev. E 111, 054117

**Electrostatic gating and the interference of chiral Majoranas in thin slabs of magnetic topological insulators**

*Oscá, Javier; Serra, Llorenç*  
Physical Review B 112, 224519

**Optimizing proximitized magnetic topological insulator nanoribbons for Majorana bound states**

*Zsurka, Eduard; Di Miceli, Daniele; Legendre, Julian; Serra, Llorenç; Grützmacher, Detlev; Schmidt, Thomas L.; Moors, Kristof*  
Physical Review B, 094504 (1-18)

**Magnetic control of the non-Hermitian skin effect in two-dimensional lattices**

*Longhi; Stefano*  
Physical Review B 112, 214208 (1-13)

**Photon-assisted stochastic resonance in nanojunctions**

*Ridley, Michael; Bellasai, Leo; Moskalets, Michael; Kantorovich, Lev; Tuovinen, Riku*  
Physical Review B, 111, 094309

**Floquet-Nambu Theory of Electron Quantum Optics with Superconductors**

*Burset, Pablo; Rousset, Benjamin; Moskalets, Michael; Flindt, Christian.*  
Physical Review B, 112, 245412

**Entanglement estimation of Werner states with a quantum extreme learning machine**

*Assil, Hajar; El Allati, Abderrahim; Giorgi, Gian Luca*  
Physical Review A 111, 022412

**Investigating layer-selective transfer learning of quantum approximate optimization algorithm parameters for the Max-Cut problem**

*Venturelli, F.A.; Das, S.; Caruso, F.*  
Physical Review A 112, 042428

**Dynamical phase transitions in two-dimensional Brownian matter**

*Silvano, Nathan O.; Barci, Daniel G.*  
Physica A: Statistical Mechanics and its Applications 665, 130482

**Reconstructing functional networks of air transport delay propagations with minimal information**

*Zanin, Massimiliano*  
Physica A: Statistical Mechanics and its Applications 659, 130318

**Global balance and systemic risk in financial correlation networks**

*Bartesaighi, P.; Diaz-Diaz, F.; Grassi, R.; Uberti, P.*  
Physica A: Statistical Mechanics and its Applications, Volume 674, 130698

**A nonlinear opportunity benefit model for human mobility prediction**

*Liu, E.; Wang, Y.; Zhao, D.; Lu, X.*  
Physica A: Statistical Mechanics and its Applications Volume 676, 130867

**A statistical complexity measure can differentiate Go/NoGo trials during a visual-motor task using human electroencephalogram data**

*Carlos, F.L.P. Carlos; Navas, M.C.; Da Paz, Í.R.S.C.; de Lucas, H.B.; Ubirakitan, M.M.; Rodrigues, M.C.A.; Aguilar Domingo, M.; Herrera-Gutiérrez, E.; Rosso, O.A.; Bavassi, L.; Matias, F.S.*  
Physica D: Nonlinear Phenomena, vol. 483, 134955

**Laser Mpemba effect**

*Longhi, Stefano*  
Optics Letters 50, 2069-2072

**Dark-state photonic entanglement filters**

*Longhi, Stefano*  
Optics Letters 50, 5101-5104

**Temporal pattern generation with tunable repetition rate using semiconductor laser periodic dynamics**

*Argyris, Apostolos*  
Optics Letters 50 (20), 6325-6328

**Lifshitz tail states in non-Hermitian disordered photonic lattices**

*Longhi, Stefano*  
Optics Letters 50, 746-749

**Virtual atom-photon bound states and spontaneous emission control**

*Longhi, Stefano*  
Optics Letters 50, 3026-3029

**Liouvillian skin effect in quantum neural networks**

*Sannia, Antonio; Giorgi, Gian Luca; Longhi, Stefano; Zambrini, Roberta*  
Optica Quantum 3 (2), 189-194

**Classical bounds on two-outcome bipartite Bell expressions and linear prepare-and-measure witnesses: Efficient computation in parallel environments such as graphics processing units**

*Márton, István; Bene, Erika; Diviánszky, Péter; Drótos, Gábor*  
Computer Physics Communications 316, 109809

**The stochastic skeleton model for the Madden-Julian Oscillation with time-dependent observation-based forcing**

*Ehstand, Noemie; Donner, Reik V.; Lopez, Cristobal; Barreiro, Marcelo; Hernandez-Garcia, Emilio*  
Nonlinear Processes in Geophysics 32, 367-382

**Certifying asymmetry in the configuration of three qubits**

*Taoutioui, Abdelmalek; Drotos, Gabor; Vértesi, Tamás*  
New Journal of Physics 27, 124501

**An integrated computational approach for diversity-sensitive personalized medicine**

*Coronel-Oliveros, Carlos; Gatica, Marilyn; Herzog, Ruben; Neri, Matteo*  
Neuroscience Volume 584, 127-137

**NAC-DBS selectively enhances memory updating without effect on retrieval**

*Pérez-Segura, Andrés; Medina, Jorge; Cerdán Cerdá, Antonio; Sánchez-Ferri, Cristina; Torres, Daniel; Mirasso, Claudio; Strange, Bryan; Eguíluz, Victor M.; Lacasa, Lucas; Canals, Santiago*  
Neuropsychopharmacology XX, 50, 1420-1429

**Inferring leader-follower dynamics in three shark species using acoustic telemetry data**

*Kreuter, Nils; Fernández-Gracia, Juan; Eguíluz, Víctor M.; Sequeira, Ana M. M.*  
Movement Ecology 13, 60

**The resistance distance is a diffusion distance on a graph**

*Estrada, Ernesto*  
Mathematics 13, 2380

**Geometries of mixed graphs in complex vector spaces.**

**Hierarchies and clusters in complex networks**  
*Estrada, Ernesto*  
Mathematical Methods for Natural Phenomena 20, 7

**The Use of Atlantic Seascapes for Marine Protected Areas Planning in the Context of the Marine Biological Diversity of Areas Beyond National Jurisdiction Agreement**

*Anabitarte, Asier; Astarloa, Amaia; Garcia-Baron, Isabel; Valle, Mireia; Chust, Guillem; Galparsoro, Ibon; Mateo, Maria; Arrizabalaga, Haritz; Eguíluz, Víctor M.; Martínez-Vicente, Victor; Fernandes-Salvador, Jose A*  
Marine Pollution Bulletin 214, 117776

**Regulating Light Refraction and Reflection Using Speed-Tailored Optical Potentials**

*Qin, Chengzhi; Liu, Menglin; Wang, Bing; Longhi, Stefano; Lu, Peixiang*  
Laser & Photonics Reviews 19, e00206 (1-11)

**Reducing blackout risk by segmenting European power grid with HVDC lines**

*Gomila, D; Carreras, B.A.; Reynolds-Barredo, J.M.; Martínez-Barbeito, M.; Colet, P.; Gomis-Bellmunt, O.*  
Journal of Modern Power Systems and Clean Energy 13, 1556 - 1567

**Directs in European air traffic management: When and why are they actually granted?**

*Esteve, Pau; Zanin, Massimiliano*  
Journal of Air Transport Management 125, 102766

**Efficient approximations of transcriptional bursting effects on the dynamics of a gene regulatory network**

*Kursawe, Jochen; Moneyron, Antoine; Galla, Tobias*  
J. Royal Society Interface 22, 20250170 .

**Computational lexical analysis of Flamenco genres**

*Rosillo-Rodes, Pablo; San Miguel, Maxi; Sánchez, David*  
J. Comput. Cult. Herit. 18, 1-29

**Phase transitions and virtual exceptional points in quantum emitters coupled to dissipative baths**

*Longhi, Stefano*

J. Appl. Phys. 138, 184401 (1-13)

**Signed graphs in data sciences via communicability geometry**

*Díaz-Díaz, F.; Estrada, E.*

Information Sciences 710, 122096

**Unravelling the universal spatial properties of coral reefs**

*Giménez-Romero, Àlex; Matías, Manuel A.; Duarte, Carlos M.*

Global Ecology and Biogeography 34, e13939 (1-12)

**Towards certification: A complete statistical validation pipeline for supervised learning in industry**

*Lacasa, Lucas; Pardo, Abel; Arbelo, Pablo; Sánchez, Miguel; Bascones, Noelia; Yeste, Pablo; Martínez-Cavas, Alejandro; Rubio, Gonzalo; Gómez, Ignacio; Valero, Eusebio; De Vicente, Javier*  
Expert Systems With Applications 277, 127169

**Estimating transmission noise on networks from stationary local order**

*Kitching, Christopher; Kauhanen, Henri; Abbott, Jordan; Gopal, Deepthi; Bermudez-Otero, Ricardo; Galla, Tobiass*  
Europhysics Letters EPL 150, 31002

**Leaf susceptibility of Macaronesian laurel forest species to Phytophthora ramorum**

*Moralejo, Eduardo; García-Muñoz, José A.; Denman, Sandra; Giménez-Romero, Àlex*  
European Journal of Forest Research 144, 363-376

**Forman–Ricci communicability curvature of graphs and networks**

*Estrada, Ernesto*  
European Journal of Applied Mathematics, 1-25

**Quantum machine learning via continuous-variable cluster states and teleportation**

*García-Beni, Jorge; Paparella, Iris; Parigi, Valentina; Giorgi, Gian Luca; Soriano, Miguel C.; Zambrini, Roberta*  
EPJ Quantum Technology 12, 63

**When dialects collide: How socioeconomic mixing affects language use**

*Louf, Thomas; Ramasco, Jose J; Sanchez, David; Karsai, Marton*  
EPJ Data Science 14, 47 (1-21)

**Exploring the spatial segmentation of housing markets from online listings**

*Abella, David; Martínez, Johann H.; Mazzoli, Mattia; Migozzi, Julien; Le Corre, Thibault; Alonso-Paulí, Eduard; Crespi-Cladera, Rafel; Louail, Thomas; Ramasco, José J.*  
EPJ Data Science 14, 34

**Evaluating Methods for Detrending Time Series Using Ordinal Patterns, with an Application to Air Transport Delays**

*Olivares, Felipe; Marín-Rodríguez, F Javier; Acharya, Kishor; Zanin, Massimiliano*  
Entropy 27, 230 (1-18)

**Quantifying Deviations from Gaussianity with Application to Flight Delay Distributions**

*Olivares, Felipe; Zanin, Massimiliano*  
Entropy 27, 354 (1-16)

**Algorithmic Approaches for Assessing Multiscale Irreversibility in Time Series: Review and Comparison**

*Zanin, Massimiliano; Papo, David*  
Entropy 27 (2), 126

**irreversibility: A Python Package for Assessing and Manipulating the Time Irreversibility of Real-World Time Series**

*Zanin, Massimiliano*  
Entropy 27, e27111146

**Quantum Mpemba Effect from Non-Normal Dynamics**

*Longhi, Stefano*  
Entropy 27, 581 (1-13)

**Optimal Distribution Planning of Solar Plants and Storage in a Power Grid with High Penetration of Renewables**

*Colet, Pere; Carreras, Benjamín A.; Reynolds-Barredo, José Miguel; Gomila, Damià*  
Energies 18, 3891

**Population structure plays a key role in community stability**

*Giménez-Romero, Àlex; Hernández, Christina; Genovart, Meritxell; Salguero Gómez, Roberto*  
Ecology Letters 28, e70272 (1-15)

**A generalizable deep learning framework for large-scale mapping of seagrass habitats**

*Giménez-Romero, Àlex; Ferchichi, Dhafer; Moreno-Spiegelberg, Pablo; Sintès, Tomàs; Matías, Manuel A.*  
Ecological Indicators 180, 114349 (1-12)

**Simple physics-based adjustments reconcile the results of Eulerian and Lagrangian techniques for moisture tracking in atmospheric rivers**

*Crespo-Otero, A.; Insua-Costa, D.; Hernández-García, E.; López, C.; Míguez-Macho, G.*  
Earth System Dynamics 16, 1483-1501

**A spatial numerical model for seagrass–herbivore interactions and the formation of reef halos**

*Llabrés, E.; Innes-Gold, A.A.; DiFiore, B.; Sintès, T.; E Madin, E.*  
Coral Reefs 44, 1587-1599

**Aging in coevolving voter models**

*Min, Byungjoon; San Miguel, Maxi*  
Chaos, Solitons and Fractals 196, 116344

**Scalar embedding of temporal network trajectories**

*Lacasa, Lucas; Marín-Rodríguez, F. Javier; Masuda, Naoki; Arola-Fernández, Lluís*  
Chaos, Solitons and Fractals 199, 1: 116599

**Complete aging in the noisy voter model enhances consensus formation**

*Llabrés, Jaume; Oliver-Bonafoux, Sara; Anteneodo, Celia; Toral, Raúl*  
Chaos, Solitons & Fractals 194, 116153

**Quantum reservoir computing in atomic lattices**

*Llodrà, Guillem; Mujal, Pere; Zambrini, Roberta; Giorgi, Gian Luca*  
Chaos, Solitons & Fractals 195, 116289

**Breaking co-existence: zealotry vs. nonlinear social impact**

*Kitching, Christopher R.; Ramirez, Lucia S.; San Miguel, Maxi; Galla, Tobias*

Chaos 35, 083133

**Breaking coexistence: Zealotry vs nonlinear social impact**

*Kitching, Christopher; Ramirez Lucia; San Miguel, Maxi; Galla, Tobias*

Chaos 35, 083133

**Speedup of an all-optical delay-based reservoir computer via input rate increase and bandwidth enhancement**

*Goldmann, Mirko; Estébanez, Irene; Mirasso, Claudio R.; Fischer, Ingo; Argyris, Apostolos; Soriano, Miguel C.*

Chaos 35, 073131

**Characterising the dynamics of unlabelled temporal networks**

*Caligiuri, Annalisa; Galla, Tobias; Lacasa, Lucas*

Chaos 35, 053122

**The role of inhibitory neuronal variability in modulating phase diversity between coupled networks**

*Brito, K. V. P.; Silva, J. M. G., Mirasso, C. R.; Matias, F. S.*

Chaos 35, 093127

**Nonlinear transport in carbon quantum dot electronic devices: Experiment and theory**

*Copeland, S.; Ryu, S.; Imai, K.; Krasco, N.; Lu, Z.; Sánchez, D.; Czubarow, P.*

Applied Physics Letters 126, 232104 (1-5)

**Quantum Mpemba effect from initial system–reservoir entanglement**

*Longhi, Stefano*

APL Quantum 2, 026133 (1-8)

**SynthATDelays: A Minimalist Python Package for the Generation of Synthetic Air Transport Delay Data**

*Büth, Carlson; Zanin, Massimiliano*

Aerospace 12, 900

**Unveiling Hidden Features of Strongly Correlated Quantum Systems Through a Complex-Network Analysis**

*Llodrà, Guillem; Zambrini, Roberta; Giorgi, Gian Luca*

Advanced Quantum Technologies, 0:e00414

**Dynamical Phase Transitions in Open Quantum Walks**

*Longhi, Stefano*

Advanced Quantum Technologies 8, e00539 (1-9)

**Modulational Instability and Dynamical Growth Blockade in the Nonlinear Hatano-Nelson Model**

*Longhi, Stefano*

Advanced Physics Research 2024, 2400154 (1-10)

**Real-time measurement of non-Hermitian Landau–Zener tunneling near band crossings**

*Zhao, Lange; Wang, Shulin; Qin, Chengzhi; Wang, Bing; Ye, Han; Liu, Weiwei; Longhi, Stefano; Lu, Peixiang*

Advanced Photonics 7, 036002 (1-10)

**The nuclear-cytoplasmic ratio controls the cell-cycle period in compartmentalized frog egg extract**

*Piñeros, Liliana; Frolov, Nikita; Ruiz-Reynés, Daniel; Van Eynde, Aleyde; Cavin-Meza, Gabriel; Heald, Rebecca; Gelens, Lendert*

Current Biology, 35, 4426-4441

**Assessing the resilience of urban truck transport networks under the COVID-19 pandemic: A case study of China**

*Yang, Y.; Liu, E.; Chen, Y.; Meng, X.; Wang, T.; Wang, H.; Zhi, D.; Song, D.; Wang, H.*

Transportation Research Part E: Logistics and Transportation Review Volume 197, 104087

**Insights from a discrete generalized beta distribution analysis of heart rate and blood pressure variability: an integrated approach to study end-stage renal disease**

*Aguado-García, A.; Lerma, C.; Echeverría, J.C.; González-Gómez, G.H.; Martínez-Mekler, G.*

Biomed. Phys. Eng. Express 12 015012

**Susceptibilities of Democratic Electoral Systems**

*Raducha, T.; Klamut, J.; Cremades, R.; Bouman, P.; Wiliński, M.*

IEEE Transactions on computational social systems, Vol. 12, n. 5

**Towards certification: A complete statistical validation pipeline for supervised learning in industry**

*Lacasa, Lucas; Pardo, Abel; Arbelo, Pablo; Sánchez, Miguel; Bascones, Noelia; Yeste, Pablo; Martínez-Cavas, Alejandro; Rubio, Gonzalo; Gómez, Ignacio; Valero, Eusebio; De Vicente, Javier*

Expert Systems With Applications 277, 127169

**a.5.2. Other Publications****Aszimmetrikus qubitkonfigurációk vizsgálata a félig eszközfüggetlen kvantumhitelesítés eszközeivel**

*Veres, Gergő; Drótos, Gábor*

Fizikai és Elektrotechnikai Szeminárium 2025 kiadványa, kiadványa, Miskolci Egyetem (Miskolc, Hungary),

**Book chapters****Impact of Climate Change on Bacteria and Viruses in Biocontrol**

*Lago, Clara; Trębicki, Piotr*

Biological Control Systems and Climate Change, (edited by Joan van Baaren, Cecile Le Lann, and Chun-Sen Ma), CABI Digital Library. 148-162.

**Individual Based Models of Language Competition**

*San Miguel, Maxi; Toral, Raul*

International Encyclopedia of Language and Linguistics, 3rd Edition, in Reference Module in Social Sciences, Elsevier

**Language Dynamics: Complex Systems Approaches**

*Heinsalu, E.; Patriarca, M.; Sánchez, D.*

in Reference Module in Social Sciences, Elsevier, (1-7)

**Opinion dynamics in social networks: from models to data**  
*Peralta, Antonio F.; Kertész, János; Iñiguez, Gerardo*  
 in Handbook of Computational Social Science (edited by Taha Yasserli), Edward Elgar Publishing, 384-407

## a.6. Presentations at conferences and academic centers

### a.6.1 Invited talks at conferences and workshops

The Geometry of Dynamics on Networks.  
*NetSci-X 2025. Indore, India.*  
 Estrada, Ernesto  
 January 14 - 17

**Quantum reservoir computing and skin effect.**  
*11th International Conference on Quantum Simulation and Quantum Walks (QSQW 2025) Naples, Italy.*  
 Zambrini, Roberta  
 January 14 - 17

**Stochastic thermodynamics of quantum jumps: entropy production, martingales and inefficient detection.**  
*ICTS Program "Quantum Trajectories" Bangalore, India.*  
 Manzano, Gonzalo  
 January 20 – February 7

**Sulfide-driven traveling pulses in seagrass meadows.**  
*16th Dynamical Systems applied on Biology and Natural Sciences (DSABNS) Naples, Italy.*  
 Gomila, Damià; Ruiz-Reynés, Daniel; Moreno-Spiegelberg, Pablo  
 January 20 - 24

**Bridging Open Quantum System Theory and Quantum Reservoir Computing.**  
*Quantum Machine Learning: theory meets experiments - Workshop 2025, University of Vienna, Austria.*  
 Sannia, Antonio  
 April 1

**Vegetation Traveling Pulses Enhance Ecosystem Resilience.**  
*SIAM Conference on Applications of Dynamical Systems (DS25) Denver, USA.*  
 Gomila, Damià; Moreno-Spiegelberg, Pablo; Rietkerk, Max  
 May 11 - 15

**Unconventional Computing with Nonlinear Photonic Systems.**  
*Machine Learning Meets Photonics Workshop, Birmingham, United Kingdom.*  
 Soriano, Miguel Cornelles  
 May 19 - 21

**Network Plasticity in Collective Social Dynamics.**  
*Science Meets Social Science (S3), Wroclaw, Poland.*  
 San Miguel, Maxi  
 May 22

**Identifying Ordinal Similarities at Different Temporal Scales with Permutation Jensen-Shannon Distance.**  
*Dynamics Days Europe 2025, Thessaloniki, Greece.*  
 Soriano, Miguel Cornelles; Porte, Xavier; Zunino, Luciano  
 May 23 - 27

**Quantum Stochastic Thermodynamics: Martingales and Inefficient Detection.**  
*Joint European Thermodynamics Conference JETC 2025. Belgrade, Serbia.*  
 Manzano, Gonzalo  
 May 25 – 30

**Introduction to Quantum Reservoir Computing.**  
*Beyond von-Neumann Computing: Leveraging Novel Physics for the Future of Computation, Aspen Center for Physics, Colorado, USA.*  
 Zambrini, Roberta  
 June 1 - 8

**Analogue processing of sequential data with quantum reservoir computing.**  
*AQC 2025, Vancouver, Canada.*  
 Zambrini, Roberta  
 June 9 - 12

**Biased versus unbiased numerical methods for stochastic simulations.**  
*Charting Complexity, hold in London, UK.*  
 Ramasco, JJ  
 June 10 - 12

**Thermodynamics of Computations with Absolute Irreversibility, Unidirectional Transitions, and Stochastic Computation Times.**  
*Stochastic Thermodynamics and Computer Science Theory II. Santa Fe, USA.*  
 Manzano, Gonzalo  
 June 16 – 20

**Emergence in language: Theoretical models and data analysis.**  
*Embracing Complexity: Principled and Practical Approaches to Emergence. Palma de Mallorca, Spain.*  
 Sánchez, David  
 June 23 - 27

**Emergence of collective learning in swarms of coupled neural networks.**  
*Embracing Complexity. Palma de Mallorca, Spain.*  
 Lacasa, Lucas  
 June 23 - 27

**The Emergence of Functional Hierarchies in the Brain.**  
*Embracing Complexity: Principled and Practical Approaches to Emergence. Palma de Mallorca, Spain.*  
 Gollo, Leonardo L.  
 June 23 – 27

**Transmission Grid Stability with Large Interregional Power Flows.**  
*Minisymposium on Dynamics of Power Grids, XLV Dynamics Days Europe, Thessaloniki, Greece.*  
 Colet, Pere  
 June 23 - 27

**Beating carnot efficiency with periodically driven chiral conductors.**  
*Comarruga International Workshop on Microwave Research and Applications. Catalunya, Spain.*  
 Lopez, Rosa; Ryu, Sungguen; Sánchez, David; Serra, Llorenç; Moskalets, Michael  
 June 29

**Nonequilibrium transition between dissipative time crystals.**  
*Limit Cycles and Synchronization Go Quantum, Dresden, Germany.*  
 Giorgi, Gian Luca  
 June 30 – July 2

**The oceans as a fluid Complexity and emergence in marine ecosystems/seascape: theory, mechanisms and data.**  
*Ischia, Italy*  
 Ser Giacomi, Enrico  
 June 30 – July 4

**Insect Vectors of *Xylella fastidiosa* in the EU: An Overview.**

*International Conference of the Mediterranean Pathology Union, Bari, Italy.*  
Lago, Clara.  
July 6 - 10

**Short External Cavity Laser-based Reservoir Computing for Fiber Transmission Data Recovery.**

*25th International Conference on Transparent Optical Networks, ICTON 2025, Barcelona, Spain.*  
Argyris, Apostolos; Fischer, Ingo  
July 7 - 10

**Lyrics information processing: The case of Flamenco.**

*ATLAS 2025 (Advanced Technologies for Language Analysis Systems). Logroño, Spain.*  
Sanchez, David  
July 8

**Thermodynamic Uncertainty Relations in Superconducting System.**

*30th Low Temperature Physics conference. Bilbao, Spain*  
Lopez, Rosa; Kim, Kun Woo; Lim, Jong Soo; Cuevas, Carlos; Belzig, Wolfgang  
July 7 – 11

**The Euclidean geometry of the Huckel molecular orbital method.**

*Advancing simulation, analysis and prediction of complex chemical systems using modern chemical graph theory and computational topology. CECAM-HQ-EPFL, Lausanne, Switzerland.*  
Estrada, Ernesto  
July 16 - 18

**Statistical physics of disordered Lotka-Volterra models.**

*Classical and Quantum Complexity in Statistical Mechanics, Molveno, Italy*  
Galla, Tobias  
July 21 - 25

**Higher-Order Interactions and Networks.**

*Complex networks: from socio-economic systems to biology and the brain. Lipari, Italy.*  
Meloni, Sandro  
July 27 – August 2

**Capturing the linguistic diversity of societies.**

*Latin American Conference on Complex Networks, LANET, Punta del Este, Uruguay.*  
Ramasco, JJ  
July 28 – August 1

**Towards Network Geometrodynamics. Directed Networks.**

*4th Latin American Conference on Complex Networks (LANET 2025). Punta del Este, Uruguay.*  
Estrada, Ernesto  
July 28 – August 1

**Field theory for mobility.**

*Workshop on Complex Systems, Buenos Aires, Argentina.*  
Ramasco, JJ  
August 4

**Quantum Kinetic Uncertainty Relations in Mesoscopic Conductors at Strong Coupling.**

*LT30 conference (Low Temperature Physics Conference), Bilbao, Spain.*  
López, Rosa; Moskalets, Michael; Ravell, Ricard; Blasi, Gianmichele; Haack, Geraldine  
August 7 – 13

**Connectómica y neurodinámica: integrando estructura y tiempo en el cerebro.**

*NeuroAI: desde las neuronas y conectomas a los engramas – UIMP. Santander, Spain.*  
Gollo, Leonardo L.  
August 25 – 29

**Modelado de los sistemas neuronales**

*NeuroAI: desde las neuronas y conectomas a los engramas – UIMP. Santander, Spain.*  
Mirasso, Claudio  
August 25 – 29

**Data-driven agent-based models in epidemiology: insights on settings and transportation.**

*EPINEXT Satellite at the Conference on Complex Systems 2025 (CCS2025) in Siena, Italy.*  
Moreno Lopez, Jesus Arturo  
September 3

**Deep and recurrent hardware neural networks folded in time.**

*European Conference on Machine Learning and PKDD 2025, Porto, Portugal.*  
Soriano, Miguel Cornelles;  
Gallicchio, Claudio  
September 15 – 19

**Quantum complex systems for machine learning.**

*18th Granada Seminar, Granada, Spain.*  
Zambrini, Roberta  
September 15 - 18

**Diffusive models on graphs.**

*The Threads of Complex Networks 2025. Florence, Italy.*  
Estrada, Ernesto  
September 16 - 19

**Anticipating tipping points by percolation in networks.**

*International Symposium ULRIKE (Understanding Linkages and Responses in Integrated Knowledge of the Earth system). Oldenburg, Germany.*  
Hernandez-Garcia, E.  
September 26

**Difusión de innovaciones. De las matemáticas a los experimentos.**

*V Encuentro Internacional sobre Ciencias y Humanidades. Cartografiando la Cultura, organizado en el marco del programa Mestizajes. San Sebastian, Spain.*  
Estrada, Ernesto  
October 13 - 16

**Quantum reservoir computing.**

*XL Trobades Científiques de la Mediterrània-Josep Miquel Vidal, IME (Institut Menorquí d'Estudis), Maò, Menorca, Spain.*  
Zambrini, Roberta  
October 15 - 17

**Criticality and Hierarchy of Temporal Dynamics in the Human Brain.**

*3th International Symposium on Biomedical Engineering in the AI-Powered Era, Shantou, China.*  
Wu, Kaichao  
October 24 – 27

### **Dynamics of random Lotka-Volterra systems.**

*Random Matrix Theory for Ecology, Economics, Finance and Statistical Physics, Bielefeld, Germany*  
Galla, Tobias  
October 27 - 31

### **Delays Inside - Insights on Delays.**

*Photonics Meets Neuroscience. Palma de Mallorca, Spain.*  
Fischer, Ingo  
October 31

### **Uncovering the Evolutionary Dynamics of *Xylella fastidiosa*: Patterns of Emergence and Host Range Expansion.**

*PhyloMAP et PHYLODYN. Paris, France.*  
Moralejo, Eduardo  
November 24 – 26

### **Noise-Induced Transitions and Symmetry-breaking in the Ising Model under Homogeneous Stochastic Fields.**

*XXI International Workshop on Instabilities and Nonequilibrium Structures. Valparaíso, Chile.*  
Raúl Toral  
December 1 – 5

## **a.6.2 Other talks at conferences and workshops**

### **Misbehaving individuals and risk perception shape epidemic spreading in contact networks.**

*CS2 Italy Conference 2025. Trento, Italy.*  
Meloni, Sandro  
January 15 - 18

### **Hybrid methods for studying and predicting the propagation of flight delays.**

*Engage2 Winter School in Belgrade, Serbia.*  
Blanco, Josu; Zanin, Massimiliano; Ramasco, José Javier  
January 26 – February 1

### **Anticipated synchronization in systems with distributed delay.**

*Workshop on Synchronization: from collective motion to brain dynamics. São Paulo, Brasil.*  
Ortiz del Campo, David; Galla, Tobias; Toral Garcés, Raúl  
February 8 - 9

### **Analysis of air traffic delay global propagation patterns.**

*CS3 in Madrid, Spain.*  
Blanco, Josu; Ramasco, José Javier; Zanin, Massimiliano  
February 19 – 21

### **Exploring the spatial segmentation of housing markets from online listings.**

*Conferencia Española de Sistemas Complejos CS3, in Madrid, Spain.*  
Ramasco, JJ  
February 19 – 21

### **Skin effect in quantum neural networks.**

*APS March meeting 2025, Anaheim, California, USA.*  
Sannia, Antonio  
March 1

### **The noisy voter model with complete and partial aging.**

*DPG Spring Meeting, Regensburg, Germany.*  
Toral, Raul  
March 16 - 21

### **A large-scale and open-source dataset of aircraft interactions.**

*2nd Workshop on open science in aviation. Delft, Netherlands.*  
López-Martín, Raúl; Zanin, Massimiliano  
April 3 - 4

### **Photovoltaic installations diffusion: modeling and analysis.**

*School on Non-equilibrium Statistical Physics, Barcelona, Spain.*  
Callau i Boix, Canigó; Toral, Raúl; Colet, Pere  
April 7 - 11

### **Reservoir Computing with Quantum Memristors.**

*Machine Learning & Quantum Physics Workshop. Obergurgl, Austria.*  
Montesinos, Daniel; Zambrini, Roberta; Giorgi, Gian Luca  
April 13 - 19

### **Fundamental Properties of Semiconductor Laser-Based Reservoir Computers.**

*Dynamics Days Europe 2025, Thessaloniki, Greece.*  
Soriano, Miguel Cornelles; Pflüger, Moritz; Mackowiak, Adam C.; Argyris, Apostolos  
May 23 – 27

### **Certifying quantum enhancements in thermal machines beyond the Thermodynamic Uncertainty Relation.**

*Joint European Thermodynamics Conference - JETC 2025. Belgrade, Serbia.*  
Almanza Marrero, José Antonio  
May 25 – 30

### **Population structure plays a key role in community stability**

*FISES'25. Santiago de Compostela, Spain.*  
Gimenez-Romero, A.  
June 18 – 20

### **Resilient spatio-temporal patterns in plant-soil systems**

*FISES'25. Santiago de Compostela, Spain.*  
Moreno Spiegelberg, Pablo  
June 18 – 20

### **Properties of information processing with semiconductor laser networks.**

*CLEO Europe-EQEC 2025, Munich, Germany.*  
Pflüger, Moritz; Infantes Llinares, Gemma; Soriano, Miguel C.; Argyris, Apostolos  
June 23 – 27

### **Structural predictability of large-scale aircraft interaction networks.**

*1st US-Europe Air Transportation Research & Development Symposium. Prague, Czech Republic.*  
López-Martín, Raúl; Zanin, Massimiliano  
June 24 - 27

### **Impact of the entomopathogenic fungus *Metarhizium brunneum* in the feeding behavior of *Philaenus spumarius* in olive plants: Implications for *Xylella fastidiosa* management.**

*International Symposium of Plant Virus Epidemiology (ISPVE). Sao Paulo, Brazil.*  
Lago, Clara; González-Mas, Natalia; Yousef-Yousef, Meelad; Fereres, Alberto; Quesada-Moraga, Ernique; Moreno, Arancha  
June 30 – July 3

**Feedforward and Feedback Inhibition Flexibly Modulates Theta-Gamma Cross-Frequency Interactions in Neural Circuits.**

*CNS\*2025 34th Annual Computational Neuroscience Meeting, Florence, Italy.*  
Chalkiadakis, Dimitrios; Sánchez-Claros, Jaime; López-Madrona, Víctor; Canals, Santiago; Mirasso, Claudio  
July 5 – 9

**An operational approach to online monitoring in quantum circuits for machine learning.**

*Young Atom Opticians Conference - YAO'25. Innsbruck, Austria.*  
Morguí Sancho, Oriol; Giorgi, Gian Luca; Manzano, Gonzalo; Zambrini, Roberta  
July 7 - 11

**Symmetry Breaking and Restoration in a Two-State System with Stochastic Fields.**

*StatPhys29 conference. Florencia, Italy.*  
Toral, Raúl  
July 13 – 18

**On the stability of competitive ecological communities with pairwise and higher-order interactions.**

*Complex Networks with Special Sessions on AI, Blockchain & New Materials a StatPhys29 satellite, Venice, Italy.*  
Meloni, Sandro  
July 21 - 23

**Evaluating worldwide air transport delay causality.**

*Complex Systems 2025 in Siena, Italy.*  
Blanco, Josu; Zanin, Massimiliano; Ramasco, José Javier  
September 1 - 5

**Exploring the spatial segmentation of housing markets from online listings.**

*Complex Systems CCS2025, Siena, Italy.*  
Ramasco, JJ  
September 1 – 5

**Quantum Reservoir Computing with Quantum Memristors.**

*XXXI International Summer School "Nicolas Cabrera" on Quantum photonic technologies. Madrid, Spain.*  
Montesinos, Daniel; Zambrini, Roberta; Giorgi, Gian Luca  
September 1 – 5

**An information-theoretic approach to quantifying correlations in precipitation data: seasonal and regional variations.**

*Complex Systems CCS2025, Siena, Italy.*  
De Gregorio, Juan  
September 1 – 5

**Data-Driven Agent-Based Reconstruction of Inter-Urban System Dynamics.**

*Complex Systems CCS2025, Siena, Italy.*  
Bellisardi Federico  
September 1 – 5

**Some lessons from the noisy-voter model: be lazy to improve consensus.**

*Complex Systems CCS2025, Siena, Italy.*  
Toral, Raúl  
September 1 – 5

**Fair Urban Zones of Emission (FUZE): Assessing impact, effectiveness and fairness of low emission zones via a Co-evolutive Agent Based Mobility Model.**

*Conference on Complex Systems 2025 (CCS2025), Siena, Italy.*  
Moreno Lopez, Jesus Arturo  
September 1 – 5

**A Theoretical Framework for Criticality and a Hierarchy of Timescales in the Brain.**

*5th Symposium of the Spanish Network for the Interaction between Computational and Cognitive Neuroscience (SINC2). Las Palmas, Spain.*  
Gollo, Leonardo L.  
September 3 – 5

**How Do We Define Dynamic Range of Complex Neuronal Response Functions?.**

*20th Meeting of the Spanish Society for Neuroscience. Las Palmas, Spain.*  
Gollo, Leonardo L.  
September 3 - 5

**Aging and Brain Criticality: Diverging Pathways of Neural Dynamics.**

*20th Meeting of the Spanish Society for Neuroscience. Las Palmas, Spain.*  
Wu, Kaichao  
September 3 - 5

**Modeling V1-LM Cortical Interactions: A Data-Driven Approach to Visual Processing in the Mouse Brain.**

*20th meeting of the Spanish Society for Neuroscience (SENC2025), Las Palmas de Gran Canaria, Spain.*  
Galván Fraile, Javier; Gil-Rodrigo, Sofia; Ito, Shinya; Haufler, Darrell; Chen, Guozhang; Mirasso, Claudio; Arkhipov, Anton.  
September 3 - 5

**On the stability of competitive ecological communities with pairwise and higher-order interactions.**

*CCS Italy 2025 conference. Bari, Italy.*  
Meloni, Sandro  
September 15 – 19

**Depeaking of airline schedules.**

*Engage2 Summer School in Braunschweig, Germany.*  
Blanco, Josu; Ramasco, José Javier; Zanin, Massimiliano  
September 21 – 27

**Propuesta metodológica para el análisis de la relación entre flujos de movilidad y siniestralidad urbana. Estudio de caso en Zaragoza.**

*II Congreso Español sobre Investigación en Movilidad, Pabellón Puente Zaha Hadid, Sede de Mobility City, en Zaragoza, Spain.*  
Pérez-López, Lourdes; Martínez, Johann H.; Ramasco, José J.; Ruiz-Varona, Ana  
October 2 – 3

**Inferring Urban Morphology through gravitational work minimization of twitter-derived trajectories.**

*II Congreso Español sobre Investigación en Movilidad. Zaragoza, Spain.*  
Bellisardi Federico  
October 2

**Stochastic Thermodynamics of Imitation Models.**

*XIII GEFENOL-DIFENSC Summer School on Statistical Physics of Complex Systems. Barcelona, Spain.*

Trigal, Lucas  
October 6 – 10

**Quantum reservoir computing using Jaynes-Cummings model.**

*ICE-10: Quantum Information in Spain.*

Das, Sreetama; Giorgi, Gian Luca; Zambrini, Roberta  
October 20 – 24

**a.6.3 Poster presentations****Minimal model for spatio-temporal excitability in plant-soil systems.**

*16th Dynamical Systems applied on Biology and Natural Sciences (DSABNS) Naples, Italy.*

Moreno-Spiegelberg, Pablo; Gomila, Damià; Rietkerk, Max  
January 20 – 24

**Comparative Analysis of Clustering Methods for Oceanic Spatiotemporal Patterns.**

*4th Nonlinear Processes in Oceanic and Atmospheric Flows (NLOA2025), Barcelona, Spain.*

Rodriguez-Mendez, V.; Lopez, C.; Hernandez-Garcia, E.; Ramasco, J.J.  
January 22 - 24

**The Madden-Julian Oscillation under time-dependent forcing: A stochastic skeleton model approach.**

*4th Nonlinear Processes in Oceanic and Atmospheric Flows (NLOA2025), Barcelona, Spain.*

Ehstand, N.; Donner, R.V.; Lopez, C.; Hernandez-Garcia, E.; Barreiro, M.  
January 22 – 24

**Numerical methods for quasi-stationary distributions.**

*Winter Workshop on Complex Systems. Lombardy, Italy.*

Oliver-Bonafoux, Sara; Aguilar, Javier; Galla, Tobias; Toral, Raúl.  
January 26 – 31

**Time and wavelength multiplexing in photonic neural networks.**

*Winter Workshop on Complex Systems 2025 Lombardy, Italy.*

Jiménez-González, Pedro; Soriano, Miguel C.; Mirasso, Claudio R.  
January 26 - 31

**Reconstruction and characterization of aircraft interaction networks.**

*Engage Winter School 2025. Belgrade, Serbia.*

López-Martín, Raúl; Zanin, Massimiliano  
January 27 – 31

**Language shift dynamics in coupled communities with linguistic preferences.**

*Winter Workshop on Complex Systems. Bergamo, Italy.*

Rosillo-Rodes, P.; San Miguel, M.; Sánchez, D.  
January 30

**Anticipated synchronization in systems with distributed delay.**

*School on Synchronization: from collective motion to brain dynamics. São Paulo, Brasil.*

Ortiz del Campo, David; Galla, Tobias; Toral Garcés, Raúl  
February 3 – 14

**Entropy and type-token ratio in gigaword corpora.**

*3rd meeting of the Spanish Chapter of the Complex Systems Society. Madrid, Spain.*

Rosillo-Rodes, Pablo; San Miguel, Maxi; Sánchez, David  
February 19

**Homogeneous pair approximation for the partisan voter model.**

*3rd Meeting of the Spanish Chapter of the Complex Systems Society. Madrid, Spain.*

Llabrés, Jaume; San Miguel, Maxi; Toral, Raúl  
February 19 – 21

**Biased versus unbiased methods for stochastic simulations.**

*3rd Meeting of the Spanish Chapter of the Complex Systems Society. Madrid, Spain.*

Toral, Raúl  
February 19 – 21

**Distributed Quantum Extreme Learning Machines.**

*Basque Country-Bordeaux Quantum Algorithms Meeting. Bayona, France.*

Gili, Marta; Giorgi, Gian Luca; Zambrini, Roberta  
April 9 - 10

**Reservoir Computing with Quantum Memristors.**

*Quantum Machine Learning: theory meets experiments, Vienna, Austria.*

Montesinos, Daniel; Zambrini, Roberta; Giorgi, Gian Luca  
April 23 - 25

**Dissipative entanglement generation by coherent collisions.**

*Mallorca Topological Quantum Matter. Palma de Mallorca, Spain.*

Bozkurt, A. Mert; López, Rosa; Ryu, Sungguen  
May 6 - 9

**Electric-field-induced conductance resonances due to Fermionic and Majorana interfering states.**

*Mallorca Topological Quantum Matter. Palma de Mallorca, Spain.*

Osca, Javier; Serra, Llorenç  
May 6 – 9

**Current and heat transport in two and three terminal QAHI+S junctions.**

*Mallorca Topological Quantum Matter. Palma de Mallorca, Spain.*

Osca, Javier; López, Rosa; Serra, Llorenç  
May 6 – 9

**Inference of irreversibility in urban mobility.**

*Stochastics processes: Inferences in complex systems. Lausanne, France.*

Trigal, Lucas  
May 14 – 16

**Characterizing the dynamics of unlabeled temporal networks.**

*NetSci 2025, Maastricht, The Netherlands.*

Caligiuri, Annalisa; Galla, Tobias; Lacasa, Lucas  
June 2 – 6

**Exploring delay propagation in air transport using temporal networks.**

*NetSci 2025, Maastricht, The Netherlands.*  
Esteve, Pau; Zanin, Massimiliano  
June 2 - 6

**flight2vec: Event embedding for flight delay prediction.**

*NetSci 2025, Maastricht, The Netherlands.*  
Esteve, Pau; Zanin, Massimiliano  
June 2 - 6

**Complex dynamics in clonal growth: Seagrass meadows as a case study**

*NoLineal 2025. Santiago de Compostela, Spain.*  
Sintes, T.; Llabrés, E.; Ruiz-Reynés, D.; Gomila, D.  
June 16 - 18

**A generalized model for clonal growth in scleractinian corals**

*FISES'25, XXV Congreso de Física Estadística. Santiago de Compostela, Spain.*  
Sintes, Tomás; Llabrés, Eva  
June 18 - 20

**Common and idiosyncratic responses of marine microbiome interactions to nutrient enrichments.**

*FISES'25, XXV Congreso de Física Estadística. Santiago de Compostela, Spain.*  
Sheykhali, Somaye; Fernández-Gracia, Juan; Melián, Carlos J.; Irigoien, Xabier; Duarte, Carlos M.; Eguíluz, Víctor M.  
June 18 - 20

**The stochastic skeleton model for the Madden-Julian Oscillation: tropical climatic variability under time-dependent forcing.**

*FISES'25, XXV Congreso de Física Estadística. Santiago de Compostela, Spain.*  
Ehstand, N.; Donner, R.V.; Lopez, C.; Hernandez-Garcia, E.; Barreiro, M.  
June 18 - 20

**Understanding 3D Ocean Transport: FSLE Insights into Vertical and Horizontal Connectivity.**

*FISES'25, XXV Congreso de Física Estadística. Santiago de Compostela, Spain.*  
Cloux, S.; Orfila, A.; Hernandez-Carrasco, I.; Lopez, C.; Hernandez-Garcia, E.  
June 18 - 20

**Excitable dynamics and coral reef formation: A simple model of macro-scale structure development.**

*FISES'25, XXV Congreso de Física Estadística. Santiago de Compostela, Spain.*  
Álvarez-Alegría, Miguel; Moreno-Spiegelberg, Pablo; Matias, Manuel A; Gomila, Damià  
June 18 - 20

**Numerical methods for quasi-stationary distributions.**

*FISES'25, XXV Congreso de Física Estadística. Santiago de Compostela, Spain.*  
Oliver-Bonafoux, Sara; Aguilar; Javier, Galla, Tobias; Toral, Raúl  
June 18 - 20

**Decoding Dynamic Microbial Interactions.**

*FISES'25, XXV Congreso de Física Estadística. Santiago de Compostela, Spain.*  
García-Castillo, Juan; Fernández-Gracia, Juan  
June 18 - 20

**Universality of noise-induced transitions in nonlinear voter models.**

*FISES'25, XXV Congreso de Física Estadística. Santiago de Compostela, Spain.*  
Llabrés, Jaume; San Miguel, Maxi; Toral, Raúl  
June 18 - 20

**Photovoltaic installations diffusion: modeling and analysis.**

*FISES'25, XXV Congreso de Física Estadística. Santiago de Compostela, Spain.*  
Callau i Boix, Canigó; Toral, Raúl; Colet, Pere  
June 18 - 20

**Anticipated synchronization in systems with distributed delay.**

*FISES'25, XXV Congreso de Física Estadística. Santiago de Compostela, Spain.*  
Ortiz del Campo, David; Galla, Tobias; Toral Garcés, Raúl;  
June 18 - 20

**Exclusive Economic Zones as agents for marine megafauna conservation.**

*FISES'25, XXV Congreso de Física Estadística. Santiago de Compostela, Spain.*  
Buenvarón-Campo, Gorca; Rodríguez, Jorge P.; Fernández-Gracia, Juan; M. Eguíluz, Víctor  
June 18 - 20

**The learning-chaos trade-off in neural network training.**

*FISES'25, XXV Congreso de Física Estadística. Santiago de Compostela, Spain.*  
Jiménez-González, Pedro; Soriano, Miguel C.; Lacasa, Lucas  
June 18 - 20

**Modeling the effect of temperature on vector-borne diseases.**

*FISES'25, XXV Congreso de Física Estadística. Santiago de Compostela, Spain.*  
Rodríguez Cababanillas, Juan Carlos; Giménez Romero, Alex; Matías Muriel, Manuel  
June 18 - 20

**Comparison of complete and partial aging in the voter model.**

*FISES'25, XXV Congreso de Física Estadística. Santiago de Compostela, Spain.*  
Toral, Raúl  
June 18 - 20

**Reducing blackout risk by segmenting the European power grid with HVDC lines.**

*FISES'25, XXV Congreso de Física Estadística. Santiago de Compostela, Spain.*  
Gomila, Damià; Carreras, Benjamín A.; Reynolds-Barredo, José M.; Martínez-Barbeito, María; Colet, Pere; Gomis-Bellmunt, Oriol  
June 18 - 20

**Transmission Grid Stability with Large Interregional Power Flows.**  
*FISES'25, XXV Congreso de Física Estadística. Santiago de Compostela, Spain.*

Martínez-Barbeito, María; Gomila, Damià; Fritzschn, Julian; Jacquod, Philippe  
June 18 – 20

**Entropy and type-token ratio in massive linguistic corpora**  
*FISES'25, XXV Congreso de Física Estadística. Santiago de Compostela, Spain.*

Rosillo, P; San Miguel, M; Sanchez, D  
June 18 – 20

**Modelling echo chamber effects in signed networks**  
*FISES'25, XXV Congreso de Física Estadística. Santiago de Compostela, Spain.*

Vendeville, A; Diaz-Diaz, F  
June 18 – 20

**Heterogeneous consensus dynamics through reaction-diffusion models on graphs/networks**  
*FISES'25, XXV Congreso de Física Estadística. Santiago de Compostela, Spain.*

Miranda, M.; Moreno-Spiegelberg, P.; Estrada, E.  
June 18 – 20

**Study of a Lotka - Volterra dynamics with random carrying capacities**  
*FISES'25, XXV Congreso de Física Estadística. Santiago de Compostela, Spain.*

Nunzi, Carlotta; Baron, Joseph W.; Galla, Tobias  
June 18 – 20

**Inferencia Termodiámica en la movilidad urbana**  
*FISES'25, XXV Congreso de Física Estadística. Santiago de Compostela, Spain.*

Trigal, L.; Manzano, G.; Fernandez, J.  
June 18 – 20

**Spatial heterogeneity controls mitotic coordination via phase-to-trigger wave transitions.**  
*Embracing Complexity: Principled and Practical Approaches to Emergence Workshop, Palma de Mallorca, Spain.*

Puls, O.; Ruiz-Reynés, D.; Tavella, F.; Jin, M.; Kim, Y.; Gelens, L.; Yang, Q.;  
June 23 - 27

**Feedforward and Feedback Inhibition Shape the Directionality of Cross-Frequency Interactions in Neural Circuits.**

*Embracing Complexity: Principled and Practical Approaches to Emergence, Palma de Mallorca, Spain.*

Chalkiadakis, Dimitrios; Sánchez-Claros, Jaime; López Madrona, Victor; Canals, Santiago; Mirasso, Claudio  
June 23 - 27

**Dynamic Range Revisited: Novel Methods for Accurate Characterization of Complex Response Functions.**

*34th Annual Computational Neuroscience Meeting, Florence, Italy.*

Gollo, Leonardo L.; Richardson, Jenna; Torres, Filipe; Copelli, Mauro  
July 5 -9

**Critical Slowing Down and the Hierarchy of Neural Timescales: A Unified Framework.**

*34th Annual Computational Neuroscience Meeting, Florence, Italy.*

Gollo, Leonardo L.  
July 5 -9

**Brain Criticality Trajectories in Aging: From Cognitive Slowing to Hyperexcitability.**

*34th Annual Computational Neuroscience Meeting, Florence, Italy.*

Wu, Kaichao; Gollo, Leonardo L.  
July 5 -9

**Disrupted Temporal Dynamics in Stroke: A Criticality Framework for Intrinsic Timescales.**

*34th Annual Computational Neuroscience Meeting, Florence, Italy.*

Wu, Kaichao; Jelfs, B.; Fang, Q.; Gollo, Leonardo L.  
July 5 -9

**Distributed Quantum Extreme Learning Machines.**

*Quantum Technologies for Young Researchers workshop. Madrid, Spain.*

Gili, Marta; Giorgi, Gian Luca; Zambrini, Roberta  
July 8 – 11

**Information-to-energy conversion in an autonomous thermal machine.**

*StatPhys 29 - 2025 Florence, Italy.*  
Trigal García, Lucas; Almanza Marrero, José A.; Manzano, Gonzalo  
July 13 - 18

**Certifying quantum enhancements in thermal machines beyond the Thermodynamic Uncertainty Relation.**

*StatPhys 29 - 2025 Florence, Italy.*  
Almanza Marrero, José Antonio  
July 13 - 18

**Dissipative entanglement generation by coherent collisions.**

*30th international conference on low temperature physics. Bilbao, Spain.*

Bozkurt, A. Mert; López, Rosa; Ryu, Sungguen  
August 7 – 13

**Thermodynamics consistency of driven dissipative systems.**

*Granada Summer School on Quantum Matter Out of Equilibrium. Spain.*

Toledo Tude, Luisa; Zambrini, Roberta; Manzano, Gonzalo  
September 1 – 5

**Structural determinants of high-order interactions in biophysical neural networks.**

*20th Meeting of the Spanish Society for Neuroscience. Las Palmas, Spain.*

Herzog, Rubén; Gollo, Leonardo L.  
September 3 – 5

**On the structure of species-function participation in multilayer ecological networks.**

*VII Symposium on Ecological Networks: EcoNet2025, Newcastle, England.*

Cuevas-Blanco, Mar; Hervías-Parejo, Sandra; Donoso, Isabel; Traveset, Anna; Lcasa, Lucas; M. Eguiluz, Victor  
September 3 -5

**Compiling Logical Circuits into Photonic Architectures with SOQCS: From Simulation to Design Tool.**

*Photonics Ireland 2025. Cork, Ireland.*

Osca, Javier; Vala Jiri  
September 3 -5

**Customizable computational model of rat brain functional connectivity.**

*20th Meeting of the Spanish Society for Neuroscience. Las Palmas de Gran Canaria, Spain.*  
Graafland, Catharina Elisabeth; Aguado Garcia, Andres Alejandro; Cabral, Joana; Mirasso, Claudio; Canals, Santiago  
September 3 - 5

**Hierarchy and Criticality in Post-Stroke Neural Dynamics: Insights from Intrinsic Neural Timescales.**

*20th Meeting of the Spanish Society for Neuroscience. Las Palmas, Spain.*  
Wu, Kaichao; Gollo, Leonardo L.  
September 5

**The learning-chaos trade-off in neural network training.**

*18th Granada Seminar Granada, Spain.*  
Jiménez-González, Pedro; Soriano, Miguel C.; Lacasa, Lucas  
September 15 - 18

**Photovoltaic installations diffusion: modeling and analysis.**

*Summer School of the Complex Systems Society - Spain (CS3), Barcelona, Spain.*  
Callau i Boix, Canigó; Toral, Raúl; Colet, Pere  
September 29 – October 3

**Feedforward and Feedback Inhibitory Circuit Balance Governs Directionality in Theta-Gamma Cross-Frequency Coupling.**

*Bernstein Conference, Frankfurt am Main, Germany.*  
Chalkiadakis, Dimitrios; Sánchez-Claros, Jaime; López Madrona, Victor; Canals, Santiago; Mirasso, Claudio  
September 29 – October 2

**Flow spatial structure determines pattern instabilities in nonlocal models of population dynamics.**

*CompSysBio2025: Advanced Lecture Course on Computational Systems Biology' - Aussois, France.*  
Silvano, Nathan; Valeriano, Joao; Lopez, Cristobal; Hernandez-Garcia, Emilio; Martinez-Garcia, Ricardo.  
October 5 - 10

**Harnessing the effect of generalized measurements on quantum circuits for temporal information processing.**

*Young Quantum Information Scientists 2025, YQIS'25 - Barcelona, Spain.*  
Morguí Sancho, Oriol; Giorgi, Gian Luca; Zambrini, Roberta  
October 6 - 10

**Anticipated synchronization in stochastic individual-based models.**

*XIII GEFENOL-DIFENSC Summer School on Statistical Physics of Complex Systems. Barcelona, Spain.*  
Ortiz del Campo, David; Galla, Tobias; Toral Garcés, Raúl;  
October 6 - 10

**Thermodynamics of periodically driven dissipative systems.**

*XL Trobades Científiques de la Mediterrània-Josep Miquel Vidal: Ciència i Tecnologies Quàntiques a la Mediterrània, Menorca, Spain.*  
Toledo Tude, Luisa; Zambrini, Roberta; Manzano, Gonzalo  
October 15 – 17

**Harnessing the effect of generalized measurements on quantum circuits for temporal information processing.**

*XL Trobades Científiques de la Mediterrània-Josep Miquel Vidal: Ciència i Tecnologies Quàntiques a la Mediterrània. Maó, Menorca, Spain.*  
Morguí Sancho, Oriol; Giorgi, Gian Luca; Zambrini, Roberta  
October 15 - 17

**Quantum sensing of a quantum field.**

*ICE-10: Quantum information in Spain. Valencia, Spain.*  
Ravell Rodríguez, Ricard  
October 20 - 24

**Thermodynamics of periodically driven dissipative systems.**

*ICE-10: Quantum Information in Spain, Valencia, Spain.*  
Toledo Tude, Luisa; Manzano, Gonzalo; Zambrini, Roberta  
October 20 – 24

**Quantum Reservoir Computing with Quantum Memristors.**

*Nanophotonics and Micro/Nano Optics International Conference 2025, Paris, France.*  
Montesinos, Daniel; Zambrini, Roberta; Giorgi, Gian Luca  
October 20 - 22

**Distributed Quantum Extreme Learning Machines.**

*ICE-10: Quantum information in Spain. Valencia, Spain.*  
Gili, Marta; Giorgi, Gian Luca; Zambrini, Roberta  
October 20 – 24

**Deep-learning-assisted simulation of a cortical circuit: Integrating anatomy, physiology and function.**

*SNUFA 2025. FMI, Basel, Switzerland.*  
Ito, Shinya; Haufler, Darrell; Galván Fraile, Javier; Dai, Kael; Aman, Joe; Zobeiri, Omid; Chen, Guozhang; Mirasso, Claudio; Maass, Wolfgang; Arkhipov, Anton  
November 5 - 6

**Open access data sets for ATM research.**

*SESAR Innovation Days 2025. Bled, Eslovenia.*  
López-Martín, Raúl; Esteve, Pau; Zanin, Massimiliano  
December 1 – 4

**Intrinsic neural timescales in interacting populations of spiking neurons.**

*IFISC Scientific Advisory Board, in IFISC, Spain.*  
Coll de San Simón Benito, Antonio; Gollo, Leonardo; Mirasso, Claudio; Wu, Kaichao; Herzog, Ruben  
December 4

**a.6.4. Seminars and Talks in other research centers**

**Rank aggregation methods for Network Meta-Analysis**

Observatory of Complex Systems of Dipartimento di Fisica e Chimica – Emilio Segrè. Palermo, Italy.  
Crisafulli, Paride  
January 7 -10

**Reservoir Computing with Quantum Memristors.**

*Walther group, part of the Quantum Optics, Quantum Nanophysics and Quantum Information group at the University of Vienna, Austria.*  
Montesinos, Daniel; Zambrini, Roberta; Giorgi, Gian Luca  
January 12 - 17

**Quantum Reservoir Computing with Complex Systems.**

*Quantum Optics, Quantum Nanophysics and Quantum Information group, University of Vienna, Austria.*  
Zambrini, Roberta  
January 13

**Anticipated Synchronization: predicting the future in real time.**

*Catalonian Politechnical University (Terrassa), Spain.*  
Toral, Raúl  
January 29

**Theoretical framework for quantum associative memory.**

*Institute of Physics, Zagreb, Croatia.*  
Giorgi, Gian Luca  
February 5 - 6

**Brain networks and modeling.**

*Complutense University of Madrid, Spain.*  
Gollo, Leonardo L.  
February 13

**Machine learning with Complex Quantum Systems.**

*Departamento Física de la Materia Condensada, Universidad de Zaragoza, Spain.*  
Zambrini, Roberta  
February 17

**Bridging Open Quantum System Theory and Quantum Reservoir Computing.**

*QuEra Computing Inc., Boston, Massachusetts, USA.*  
Sannia, Antonio  
March 1

**De palos va la cosa: un análisis del flamenco con inteligencia artificial.**

*Universitat Sénior, Universitat Politècnica de València, Spain.*  
Rosillo-Rodes, P.  
March 12

**Thermodynamics of Computations.**

*Department of Philosophy of Science and Technology of Computer Simulation at the High Performance Computing Center in Stuttgart, Germany (online).*  
Manzano, Gonzalo  
March 21

**Ciencia y arte: dos caras de la misma moneda.**

*"Aproximaciones innovativas al arte desde la ciencia: el flamenco computacional". UNED, Illes Balears, Spain.*  
Rosillo-Rodes, P;  
May 9

**The Huanglongbing Workshop and Epidemiology Course.**

*Course in Varadero, Cuba.*  
Lago, Clara  
June 9 -14

**Quantum reservoir computing based on optical memristors.**

*Department of Physics and Astronomy of the University of Turku, Finland.*  
Montesinos Capacete, Daniel  
August 6

**Quantum Kinetic Uncertainty Relations in Mesoscopic Conductors at Strong Coupling.**

*Freie Universität Physics Department Berlin, Germany.*  
Estrada, Ernesto  
September 17 – 21

**Lexical Investigation into Flamenco Lyrics.**

*SCRaPS Seminar Series at the University of Vermont, Burlington, Vermont (USA).*  
Rosillo-Rodes, P.  
September 30

**Towards network geometrodynamics. Directed graphs.**

*Q-Math seminar at Instituto de Ciencias Matemáticas (ICMAT), Madrid, Spain.*  
Estrada; Ernesto  
October 10

**Can we define climate by means of an ensemble? A tale of time scales of convergence.**

*Department of Theoretical Physics, Eötvös Loránd University, Budapest, Hungary.*  
Drótos, Gábor  
October 14

**A real-world use of self-testing.**

*Research Center for Quantum Information, Institute of Physics, Slovak Academy of Sciences, Bratislava, Slovakia.*  
Drótos, Gábor  
October 28

**Quantum reservoir computing using James-Cummings model.**

*IIT Hyderabad, India.*  
Das, Sreetama.  
November 10

**Quantum reservoir computing using James-Cummings model.**

*Tata Institute of Fundamental Research, Hyderabad, India.*  
Das, Sreetama.  
November 12

**Quantum reservoir computing using James-Cummings model.**

*International Institute of Information Technology (IIIT), Hyderabad, India.*  
Das, Sreetama.  
November 13 -14

**Quantum reservoir computing using James-Cummings model.**

*IIT Dhanbad, India.*  
Das, Sreetama.  
November 21

**Can we define climate by means of an ensemble? A tale of time scales of convergence.**

*Complexity Science Hub, Vienna, Austria.*  
Drótos, Gábor  
November 27

**a.7. Other Activities****a.7.1. Master Thesis****Synchronization in coupled laser networks**

Mackowiak Pellón, Adam César (supervisors: Argyris, Apostolos; Soriano, Miguel C.)  
November 21

**How interactions and connectivity in social media networks mediate language use**

Carpio Rivas, David Mateo (supervisors: Ramasco, José J.; Sánchez, D.)  
September 26

### Neural Networks in Deep Quantum-Classical Architectures

Mateu Coll Comas (Supervisors Zambrini, Roberta; Giorgi, Gian Luca)  
September 26

### Quantum adiabatic computation via bifurcation for solving combinatorial problems

Gallardo Calleja, Pablo (Supervisors Zambrini, Roberta; Giorgi, Gian Luca)  
September 30

### Quantum dynamics of solitons in a relativistic field equation

Cucurull, Joan (Supervisor: Gomila, Damià)  
October 13

### Reduced Intrinsic Neural Timescales in Schizophrenia during Predictive Coding

Sergio Zucchi Mesía (supervisors: Leonardo L. Gollo and Claudio Mirasso)  
September 29

### Monitoring the Resilience of Seagrass Meadows from Satellite Meadows from Satellite Imagery Using Machine Learning

del Campo González, Elena (Supervisors: Matias, Manuel A.; Giménez-Romero, Á.)  
July 28

### Quantum reservoir computing with metastable dynamics

Cañellas García, Albert (Roberta Zambrini and Gian Luca Giorgi)  
July 22

### Analysis of Large Financial Correlation Matrices

Palacín i Borrel, Laia (Supervisor Colet, Pere)  
June 12

## a.7. 2. Research stays in other centers

### University of Hawaii.

*Visitor researcher at the Hawaii Institute of Marine Biology, as a part of a Marie-Curie Global fellowship.*

Llabrés, Eva  
October 1, 2023 to April 1, 2025

### Observatory of Complex Systems of Dipartimento di Fisica e Chimica – Emilio Segrè. Palermo, Italy.

Crisafulli, Paride  
January 7 - 10

### Queen Mary University of London, UK.

Lacasa, Lucas  
April 10 - 15

### Università di Bologna (Bo) Italy.

*City Science Laboratory.*  
Bellisardi Federico  
May 24 – June 3

### Dynamics of entanglement thermal engines and Bell inequalities, Geneva, Italy.

*Scientific visit to group of Dr. Géraldine Haack, University of Geneva..*  
Ryu, Sungguen  
June 9 – July 6

### Vermont Complex Systems Institute, University of Vermont, Burlington, VT, USA.

Rosillo-Rodes, P.  
August 29 – November 29

### International Center for Theoretical Physics (Trieste) Italy.

Almanza Marrero, José Antonio  
September 1 – November 29

### Scuola Normale Superiore di Pisa (NEST / Planckian), Italy.

*Scientific visit to Francesco Caravelli, head of the Theory Group of Planckian.*  
Manzano, Gonzalo  
September 10 – December 12

### Central European University, Vienna, Austria.

Llabrés, Jaume  
September 15 – December 13

### ICTP Trieste, Italy.

*Scientific visit to ICTP in the context of CoQuSy and CoQuaDis projects.*  
Manzano, Gonzalo  
October 10 - 15

### Sorbonne University (Paris) France.

*Experimental team in Paris.*  
Montesinos, Daniel  
October 17 – 18

### King Abdullah University of Science and Technology - Kingdom of Saudi Arabia.

*Visitor researcher as participant of KCRI-ENCOREDAT project.*  
Álvarez-Alegría, Miguel  
October 19 – 30

### Maynooth University (Maynooth) Ireland.

Osca, Javier  
October 25 – November 2

### CEAB-CSIC (Centro de Estudios Avanzados de Blanes). Girona, Spain.

*Research stay at the group of Prof. Daniel Oro.*  
Matias, Manuel A.  
December 11 – 19

## a.8. Press and Media

The titles are linked to the document or media clip

### a.8.1 Press and digital Media

#### Interview to Roberta Zambrini, scientific investigator of CSIC in the “Instituto de Física Interdisciplinar y Sistemas Complejos” (IFISC)

*Quantum Spain*  
January 13

#### Xylella fastidiosa: la bacteria que deseca Alicante y Baleares y que ahora amenaza a Extremadura

*La Marea*  
January 30

#### Estos son los países con un mayor riesgo de saturar su capacidad de basura

*Enfoque Noticias*  
January 3

#### Descubren cómo se sincroniza la multitud durante el chupinazo de San Fermín: la masa oscila cada 18 segundos

*El Diario*  
February 5

#### Un estudio sugiere que el cambio climático abre la puerta a una enfermedad de la vid que Europa esquivó hace 150 años

*CSIC Agronews Castilla y León Siete Días Marbella Phytoma Observatorio Tecnológico del Vino*

*La marea*  
Islas Balears 24 horas  
Extremadura digital 24 horas  
Noticias de Huelva  
Santaigo 24 horas  
Noticias de Cantabria  
Burgos digital 24 horas  
Alicante 24 horas  
Ourense 24 horas  
Castellón 24 horas  
Noticias de Santander  
Bilbao 24 horas  
El portal UCO  
Vigo 24 horas  
Canal Racing  
Toledo digital 24 horas  
Vitoria 24 horas  
Torrelavega 24 horas  
Córdoba 24 horas  
Europa 24 horas  
Palmplona 24 horas  
Cádiz 24 horas  
Sevilla 24 horas  
Valencia 24 horas  
February 7  
**The 'Elegant' Math Model That Could Help Rescue Coral Reefs**  
*Quanta Magazine*  
February 26

**El cambio climático global abre la puerta a una enfermedad de la vid que Europa esquivó hace 150 años**  
*NCYT*  
March 4

**Científicos de la UIB participan en un estudio sobre los patrones de las plantas en función del estado de su ecosistema**  
*Última Hora*  
*El diari de la UIB*  
March 14

**La teleportació, possible?**  
*Ciència Oberta*  
March 15

**Daniel Montesinos obté una beca doctoral INPhINIT de la Fundació la Caixa**  
*El diari de la UIB*  
March 18

**Desde Ronda a Baleares para cambiar la inteligencia artificial**  
*Diario Sur*  
March 24

**A una semana del apagón histórico en España: qué se sabe y por qué se vivió otro lunes negro**  
*Clarín*  
May 5

**Internal Feedback Shapes Coral Reefs**  
*Physics*  
May 28

**UN-backed research team shows benefits of tracking ocean giants for marine conservation**  
*EurekAlert!*  
*Marine Biological Association*  
*UC Santa Cruz*  
*ANU Reporter*  
*Upwell*  
*Centre for Functional Ecology (CFE)*  
*ScienMag*  
*FishFocus*  
*Mirage News*  
*Newswise*  
*EurAsia Review*  
June 5

**Estudo global rastreia trajetos de mais de 12 mil animais marinhos**  
*Pesquisa Fapesp*  
June 5

**We tracked 13,000 giants of the ocean over 30 years, to uncover their hidden highways**  
*The Conversation*  
June 5

**Lancaster scientist contributes to study showing benefits of tracking ocean giants for marine conservation**  
*Lancaster University*  
June 5

**Mapping ocean giants: Marine megafauna study finds protected areas miss critical habitats**  
*Phys.org*  
June 5

**We tracked 13,000 giants of the ocean over 30 years, to uncover their hidden highways**  
*inkl*  
June 5

**We tracked 13,000 giants of the ocean over 30 years, to uncover their hidden highways**  
*Phys.org*  
June 6

**Entendiendo procesos de desertificación gracias a la física de sistemas complejos. El ejemplo de la Posidonia oceanica**  
*Fundación Sicómoro*  
June 6

**La megafauna marina existe, no hemos buscado donde correspondía**  
*La Razón*  
June 6

**Proteger el 30 % de los océanos no es suficiente**  
*The Conversation*  
June 6

**We tracked 13,000 giants of the ocean over 30 years, to uncover their hidden highways**  
*MSN*  
June 6

**Mapping Megafauna Exposes Gaps in Ocean Conservation**  
*Meteored UK*  
June 7

**400 científicos están siguiendo a los grandes tiburones para salvar los océanos, esto es lo que han aprendido**  
*National Geographic*  
June 7

**Tracking the ocean's giants - Welsh university plays key role in marine conservation efforts**  
*Nation.Cymru*  
June 7

**Ny studie: Havets kjemper i fare**  
*ABC Nyheter*  
June 7

**Satellite tracking reveals ocean giants are in trouble**  
*Digital Journal*  
June 8

**Marine megafauna face growing threats - despite global protections**  
*Earth*  
June 8

**Ocean Giants in Trouble: Satellite Tracking Reveals Alarming Data**  
*World Today News*  
June 8

**Pronta la mappa degli spostamenti dei grandi animali marini**  
*Alto Adige*  
*ANSA.it*  
June 8

**Ocean Giants at Risk: 12,000 Marine Animals Tracked**  
*Mirage News*  
June 8

**Satellite tracking of 12,000 marine animals reveals ocean giants are in trouble**  
*Science Daily*  
June 8

**Movimento de investigação global apoiado pela ONU mostra benefícios da localização dos gigantes do oceano para a conservação marinha**  
*Green Savers*  
June 9

**Xylella fastidiosa: Todbringender Eindringling**  
*Natur.de*  
June 26

**Un estudio dirigido desde Mallorca identifica las regiones claves del océano para conservar la megafauna marina**  
*Diario de Mallorca*  
July 1

**Models matemàtics avançats per estudiar com les espècies marines s'estructuren per sobreviure**  
*El diari de la UIB*  
July 30

**Un latido oculto en el arrecife: dos modelos revelan cómo crecen y resisten los corales ante la crisis climática**  
*Eldiario.es*  
August 19

**Der Todbringer**  
*Bild der Wissenschaft*  
August 21

**La autopista invisible de los océanos**  
*Diario de Mallorca*  
September 2

**Los ritmos cerebrales revelan cómo el cerebro elige las rutas para procesar la información**  
*CSIC*  
*Instituto de Neurociencias de Alicante*  
*Delegación Comunitat Valenciana*  
*Salud a Diario*  
September 16

**Físicos buscan la tecnología del futuro: ordenadores de fotones, más rápidos y menos contaminantes**  
*Eldiario.es*  
September 20

**Unos pocos grados de diferencia pueden marcar la frontera entre la vida y la muerte de la vid**  
*The Conversation*  
September 25

**La Nit de la Recerca moviliza este viernes en Baleares a más de 70 investigadores para divulgar la ciencia**  
*Última Hora*  
*Mallorca Diario*  
*Diario de Mallorca*  
*Delegación del CSIC en Balears*  
*Govern de les Illes Balears*  
*Pasión por el Mar*  
*dBalears*  
*UEP Mallorca*  
September 26

**Supercomputación para descifrar el Mediterráneo**  
*ABC*  
September 29

**Un estudio alerta del alto riesgo de expansión de 'Xylella' en los viñedos**  
*Última Hora*  
October 4

**Científicos estudian la vida social de los tiburones y descubren que las hembras grandes también son líderes**  
*Eldiario.es*  
October 20

**“A la vida y la muerte de la vid la separan unos pocos grados de diferencia, pero el cambio climático desprotege a los viñedos y la producción de vino de este patógeno”**  
*La Vanguardia*  
October 25

**El CSIC pone en marcha Epidemiradar: una herramienta ciudadana para vigilar la gripe y el COVID-19 en España**  
*CSIC*  
*Salud a Diario*  
*Estrella Digital*  
October 30

**El CSIC pone en marcha una herramienta ciudadana para ayudas a vigilar la gripe y el COVID-19 en España**  
*Infobae*  
*Servimedia*  
October 30

**Lanzan Epidemiradar, una plataforma online para que notifiques si tienes gripe o Covid 65 y más**  
October 31

**El CSIC lanza epidemiradar para vigilar la gripe y el covid-19 en España, que ya remontan**  
*Meteored*  
October 31

**‘Epidemiradar’ es la nueva herramienta del CSIC que convierte a la ciudadanía en aliada contra la gripe y la covid-19**  
*La Sexta*  
November 3

**La biología de sistemas y el ejemplo de la formación de la columna vertebral**  
*Fundación Sicómoro*  
November 26

**Celebrating the 2024 Edward N. Lorenz Early Career Award Winners**  
*AIP Publishing*  
December 3

**Differences between adults and juveniles enhance ecosystem stability**  
*CEAB*  
*Siglo XXI*  
*Servimedia*  
*Atres Media*  
December 11

## a.8.2 Radio and TV

**Esculls de coral amb Àlex Giménez**  
*Arran de Mar, Tarragona Ràdio*  
January 22

**Interview to Daniel Montesinos**  
*Radio Sicómoro*  
March 3

**La intermitencia puede generar patrones de Turing**  
*Radio Sicómoro*  
March 21

**Interview to Damià Gomila**

*Nautilus, IB3 Ràdio*  
March 29

**Capturando la diversidad de las sociedades multilingües**

*Radio Sicómoro*  
April 7

**Interview to Pablo Rosillo**

*Radio Sicómoro*  
April 28

**En busca de las causas del apagón**

*La Hora de la 1, RTVE*  
May 1

**Episodio 36: La red por la que viaja nuestra basura**

*Radio Sicómoro*  
September 8

**Sistemas Complejos con Ernesto Estrada**

*Cuentos Cuánticos*  
September 12

**Interview to Claudio Mirasso**

*Informatiu dematí, IB3 Ràdio*  
September 17

**Interview to Pere Colet (Best Teacher Award)**

*Radio Sicómoro*  
September 29

**Física, Lingüística y Flamenco.****Interview to Pablo Rosillo**

*Oscilador Armónico*  
October 1

**Hem aturat la xil-lela?**

*IB3 Notícies, IB3 Televisió*  
October 3

**Interview to Raúl Toral (Best Teacher Award)**

*Radio Sicómoro*  
October 27

**La Física de la Complejidad.****Interview to Maxi San Miguel**

*Oscilador Armónico*  
November 5

